



**Jamna Auto Industries Ltd.**

*"Taking Weight Lightly Since 1954"*

# Trailer Air Suspension

Capacity 12.5 Tonnes

Air Suspension  
Module

Air Suspension  
with Lift Module



INDIA'S  
**No. 1**

**SUSPENSION**  
Manufacturer in C.V.

## Air Suspension Module

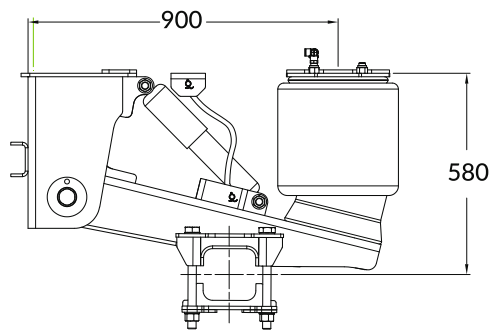
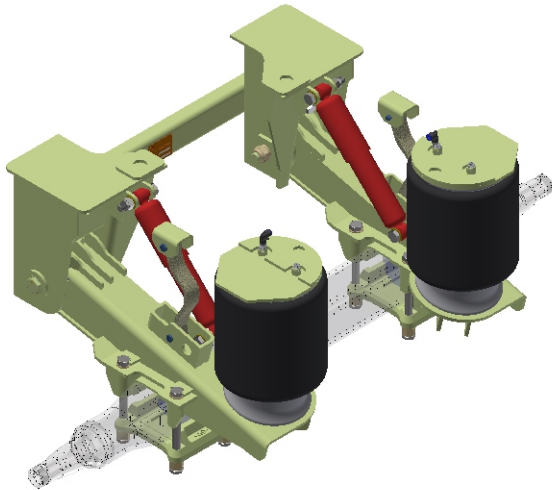

## Air Suspension with Lift Module

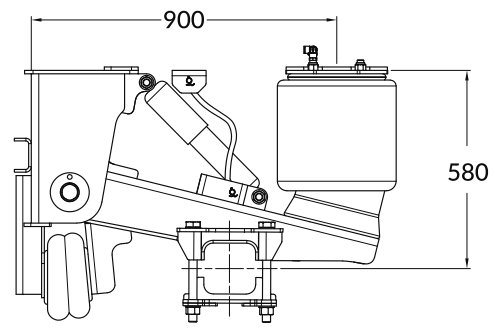
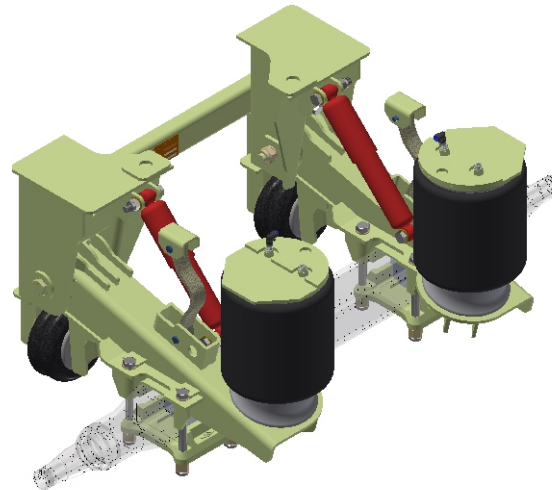

### Features & Benefits of JAI Trailer Air Suspension :-

1. Available with Axle Lift mechanism
2. Large Air Spring for heavy load & better ride comfort
3. Heavy Shock Absorbers to reduce rough road vibrations
5. Rebound control feature
6. Longer service life and easy serviceability
7. Superior Driver comfort and equipment protection
8. Tested at ARAI & In-house for worst operating level of vehicles

### Technical Specifications :-

1. Heavy-duty 12.5 Tonne capacity
2. Ride height - 580 mm
3. Axle lift up to 130 mm
4. Available in Mono, Twin & Tridem combination
5. Suitable for standard Axle Beam with 135/145/150 mm square section
6. Suitable for Trailer Spring centre - (952 for 1840 track Axle & 1052 for 1940 track Axle)

### Benefits of Axle Lift module :-

1. Lower fuel consumption and higher tire life
2. Designed for more ground clearance
3. Easy installation

# COMPONENTS

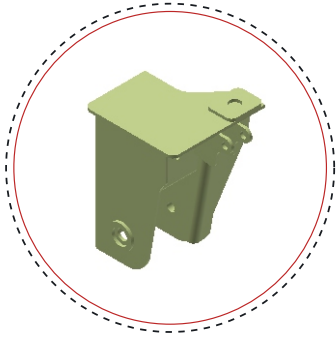

**HANGER BRACKET**

- 10 mm steel thickness
- High tensile strength steel
- Reinforced at critical area for better durability

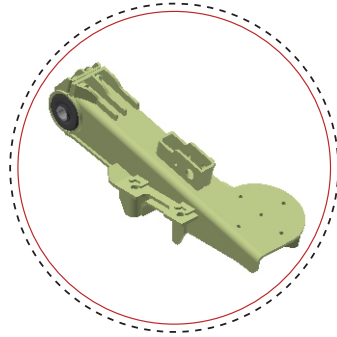

**SUSPENSION ARM**

- 10 mm steel thickness
- High tensile strength steel



**AIR SPRING**

- Large & heavy-duty Air Spring
- Natural rubber with higher fatigue life
- Higher shelf life
- Integrated rubber bump stopper

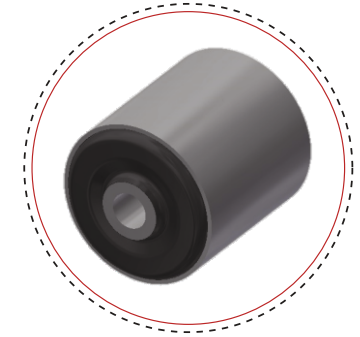

**PIVOT BUSHING**

- Double bonded rubber-steel bush has longer life
- Maintenance free bushing
- Rubber bushing absorbs road shock while maintaining lateral tracking and superior roll resistance



**SHOCK ABSORBER**

- Heavy duty shock absorber with better damping characteristics
- Triple function & high temperature seal
- Protects Air Spring from over pull

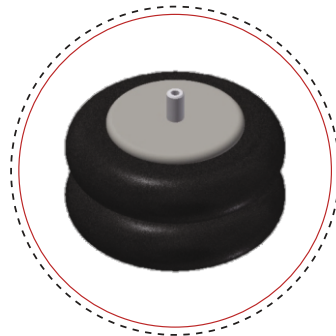

**LIFT AIR SPRING**

- Natural rubber with higher fatigue life
- Higher shelf life
- Integrated rubber bump stopper



**REBOUND STRAP**

- Heavy duty strap

# ABOUT JAMNA AUTO INDUSTRIES LTD.



India's No.1  
Leaf Spring brand



A complete  
Suspension system  
solutions provider  
for commercial  
vehicles



World's No.2  
Leaf Spring  
brand with  
capacity  
2,40,000  
MTPA



9 state-of-the-art  
plants strategically  
located in close  
proximity to OEMs



Manufactures  
5000+ part  
numbers of Leaf  
Springs  
in Aftermarket  
India



70% OEM  
Share of Business



Strongest  
Aftermarket Network  
in India consisting  
Distributors (300+),  
Retailers (6000+) &  
Mechanics (13000+)  
with presence in 465  
cities in India



One & Only  
in-house R&D centre  
in India for Springs



Recently introduced  
new range of Spring  
Allied Components  
and Lift Axle spares



**Jamna Auto Industries Ltd.**

**Registered Office**

Jai Spring Road, Industrial Area  
Yamuna Nagar - 135 001  
Ph. & Fax No. 01732-251810/11/14

**Pune Plant**

T-139, T-Block, Bhosari  
MIDC, Pimpri-Chinchwad,  
Pune - 411026

Web : [www.jaispring.com](http://www.jaispring.com) | Email : [suspension@jaispring.com](mailto:suspension@jaispring.com)