



# Jamna Auto Industries Limited

Investor Presentation

Q2 FY 23-24



This presentation and the accompanying slides (the “Presentation”), have been prepared by Jamna Auto Industries Limited (the “Company”), have been prepared solely for information purposes and do not constitute any offer, recommendation or invitation to purchase or subscribe for any securities, and shall not form the basis or be relied on in connection with any contract or binding commitment whatsoever. No offering of securities of the Company will be made except by means of a statutory offering document containing detailed information about the Company.

This Presentation has been prepared by the Company based on information and data which the Company considers reliable, but the Company makes no representation or warranty, express or implied, whatsoever, and no reliance shall be placed on, the truth, accuracy, completeness, fairness and reasonableness of the contents of this Presentation. This Presentation may not be all inclusive and may not contain all of the information that you may consider material. Any liability in respect of the contents of, or any omission from, this Presentation is expressly excluded.

Certain matters discussed in this Presentation may contain statements regarding the Company’s market opportunity and business prospects that are individually and collectively forward-looking statements. Such forward-looking statements are not guarantees of future performance and are subject to known and unknown risks, uncertainties and assumptions that are difficult to predict. These risks and uncertainties include, but are not limited to, the performance of the Indian economy and of the economies of various international markets, the performance of the industry in India and world-wide, competition, the company’s ability to successfully implement its strategy, the Company’s future levels of growth and expansion, technological implementation, changes and advancements, changes in revenue, income or cash flows, the Company’s market preferences and its exposure to market risks, as well as other risks. The Company’s actual results, levels of activity, performance or achievements could differ materially and adversely from results expressed in or implied by this Presentation. The Company assumes no obligation to update any forward-looking information contained in this Presentation. Any forward-looking statements and projections made by third parties included in this Presentation are not adopted by the Company and the Company is not responsible for such third party statements and projections.



Q2 FY 23-24  
Financial Updates

# Financial Trends - QoQ



All figures are in INR crores

	Q2 FY 23-24	Q1 FY 23-24	Q2 FY 22-23
NET SALES	607	575	553
EBITDA	81/13.3%	74/12.9%	63/11.4%
PBT	69/11.3%	63/10.9%	52/9.4%
CASH ACCRUALS	61	57	48

Cash Accruals: PAT+ Depreciation

# Financial Trends - YoY



All figures are in INR crores

	H1 FY 23-24	H1 FY 22-23	FY 22-23
NET SALES	1,183	1,100	2325
EBITDA	155/13.1%	124/11.3%	273/12%
PBT	132/11.1%	103/9.3%	229/9.9%
CASH ACCRUALS	118	95	209

Cash Accruals: PAT+ Depreciation

# Profit & Loss Statement

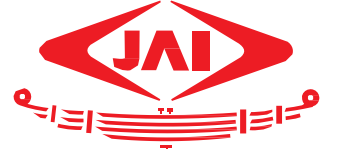

## Consolidated QoQ

All figures are in INR crores

Particulars	Q2 FY 23-24	Q2 FY 22-23	YoY	Q1 FY 23-24	QoQ
Net Sales	607	553	10%	575	6%
EBITDA	81	63	28%	74	9%
PBT	69	52	32%	63	10%
PAT	50	37	34%	46	10%

# Profit & Loss Statement

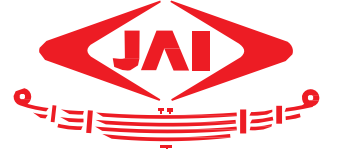

## Consolidated YoY

All figures are in INR crores

Particulars	H1 FY 23-24	H1 FY 22-23	YoY	12 Months FY 22-23
Net Sales	1,183	1100	7%	2325
EBITDA	155	124	24%	273
PBT	131	103	28%	230
PAT	96	75	28%	168

# Revenue Mix



## Product Mix

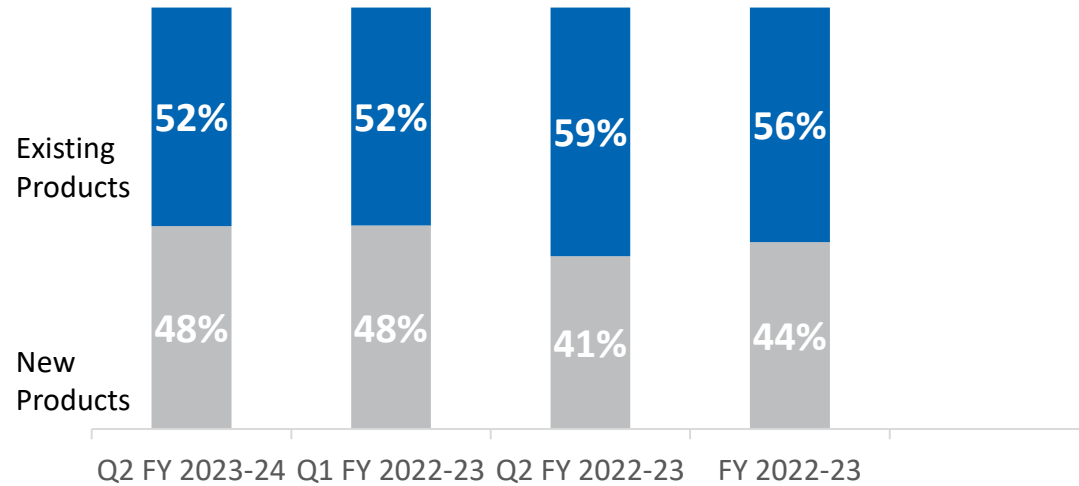

Lakshya Target: **50%** revenue from New Products by FY 2026-27

## Market Mix

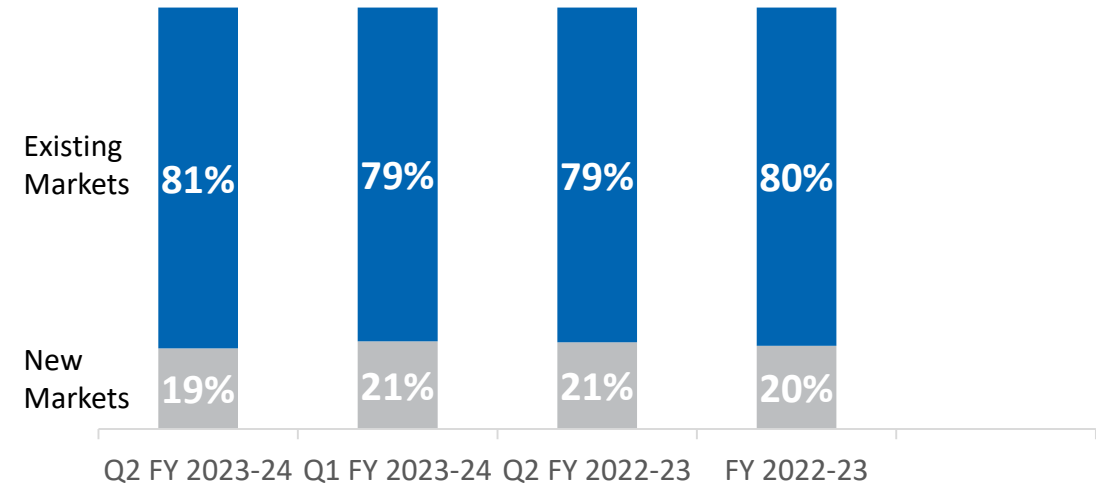

Lakshya Target: **50%** revenue from New Markets by FY 2026-27





# Industry Highlights

# Industry Highlights



All figures are in '000

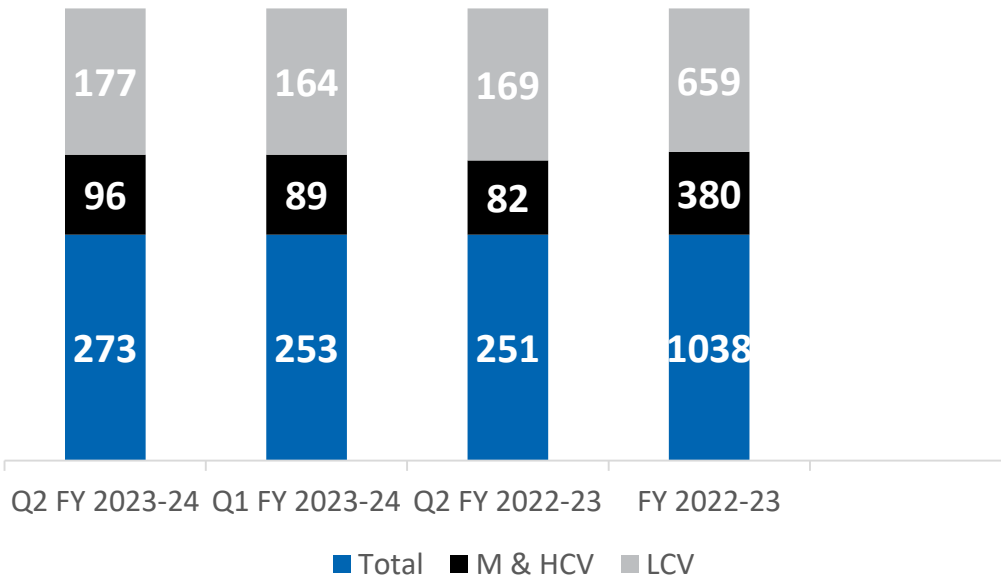

Data Source-SIAM

## CV production changes

- ↑ - Q2 FY24 vs Q1 FY23 - 8% Increase
- ↑ - Q2 FY24 vs Q2 FY23 - 5% Increase

## M&HCV production changes

- ↑ - Q2 FY24 vs Q1 FY24 - 8% Increase
- ↑ - Q2 FY24 vs Q2 FY23 - 17% Increase

For the Quarter

QoQ Change %	YoY Change %
8%	5%
8%	17%
8%	9%





Company  
Overview

# JAI at a Glance





 **Foundation**  
JAI is a renowned suspension manufacturer for commercial vehicles.

 **World class Manufacturing Infrastructure**  
10 Manufacturing units including 1 In-house R&D center



- More than 16,000 touch points
- JAI Shoppe in Sanjay Gandhi Transport Nagar, Delhi which is one of the largest trucking center in India.

 **Manufacturing**  
~300+ OEM parts  
~5,000+ AMI parts

 **Sound Financials**  
CRISIL A1+/AA-

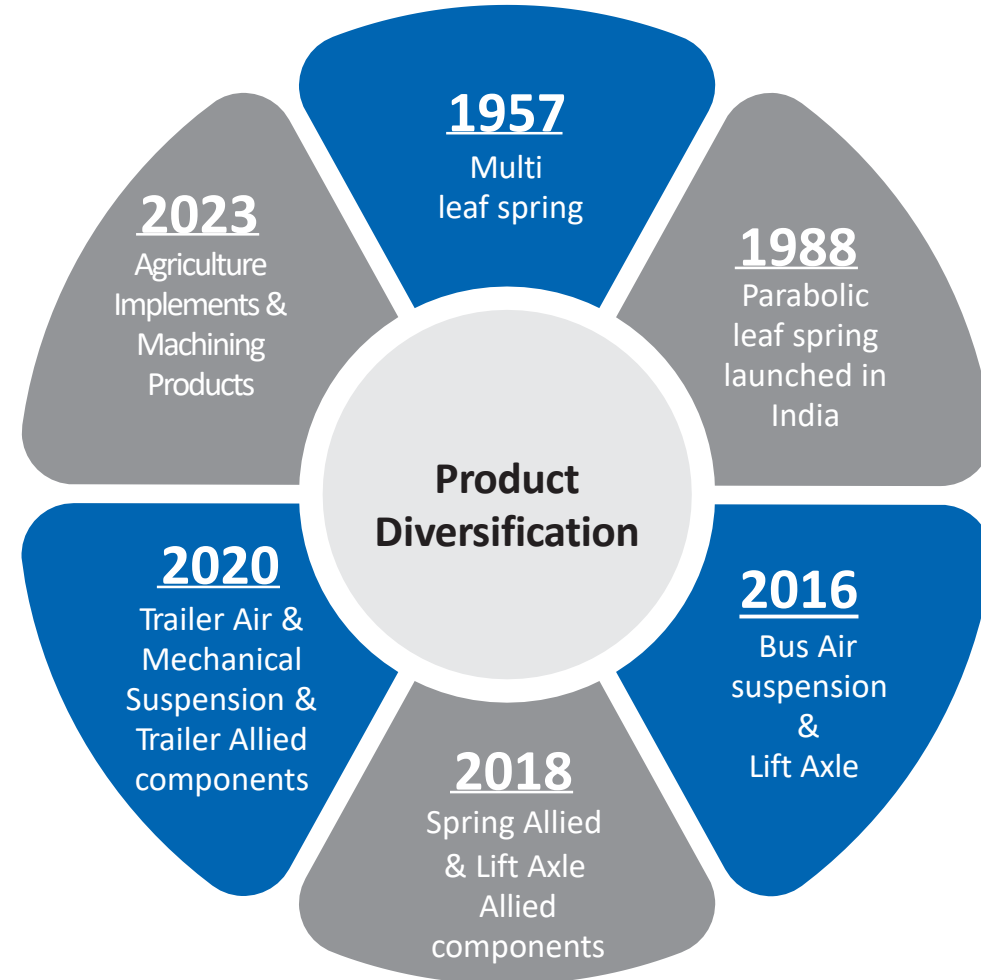

# Jai's Plants : Strategically Located Across OEM Plants

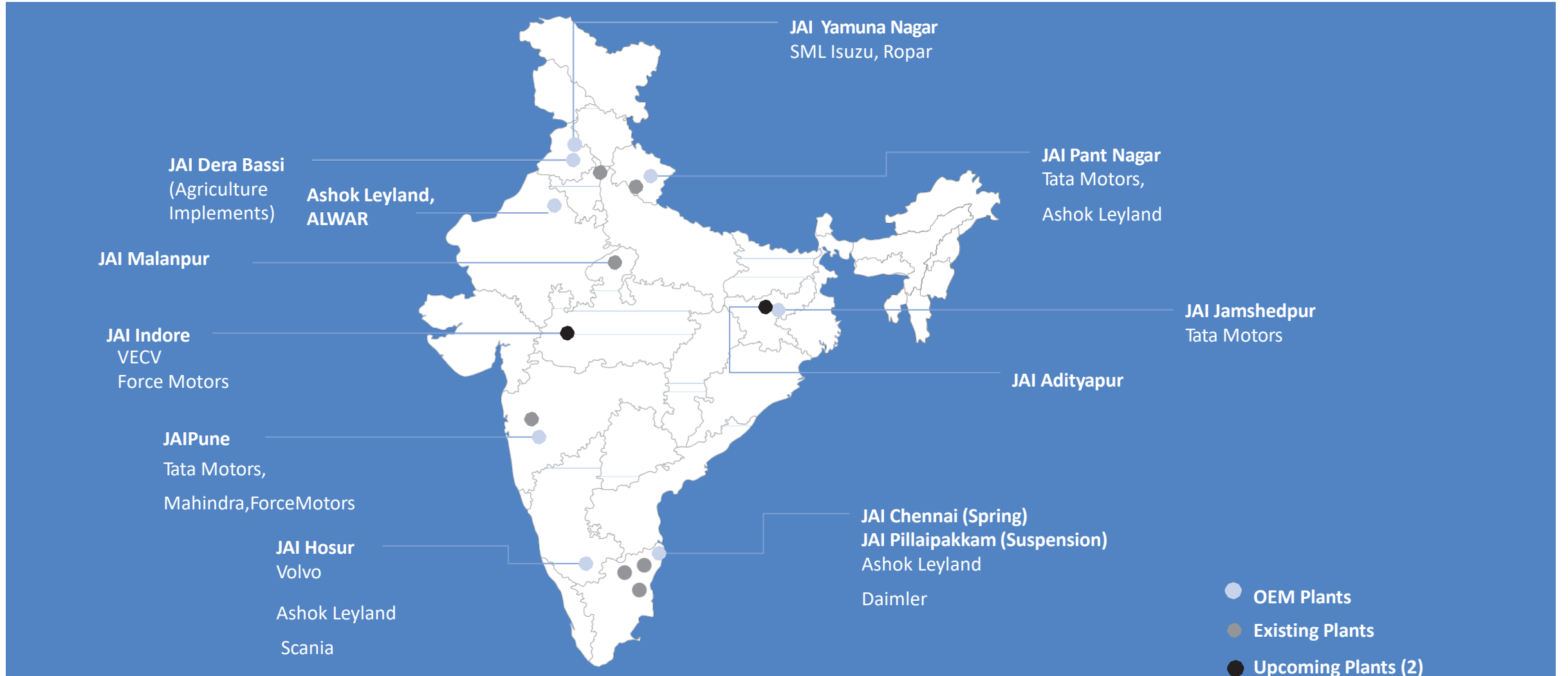

Note – Maps not to scale. All data, information, and maps are provided “as is” without warranty or any representation of accuracy, timeliness or

# JAI's OEM Customers



# JAI's Product Portfolio

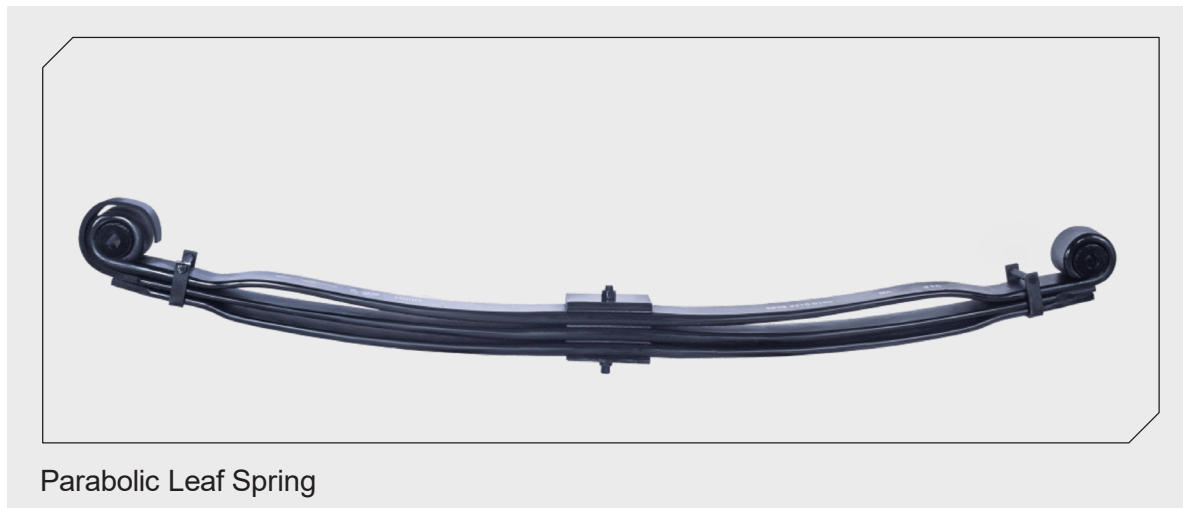
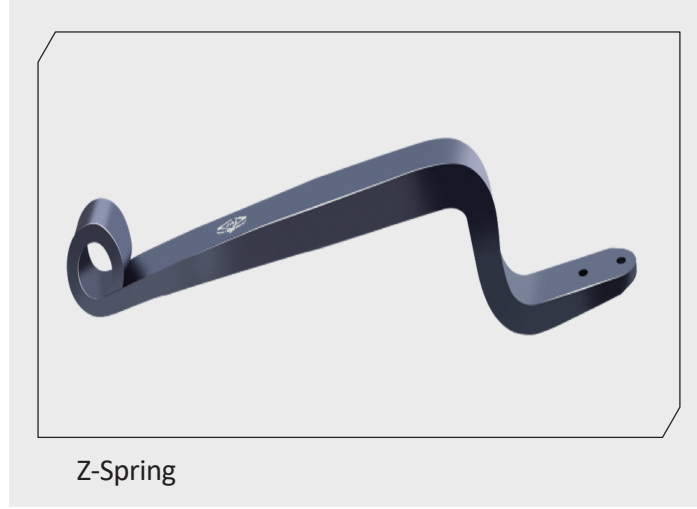

# JAI's Product Portfolio

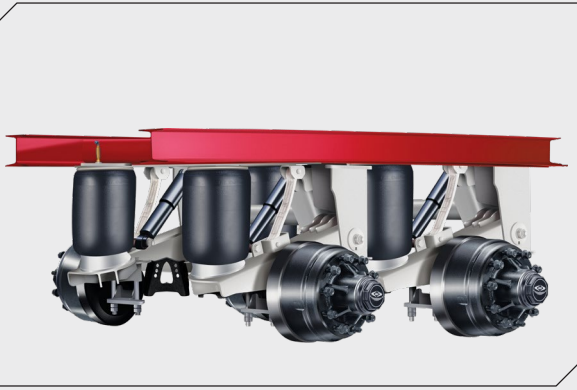

Bus Air Suspension

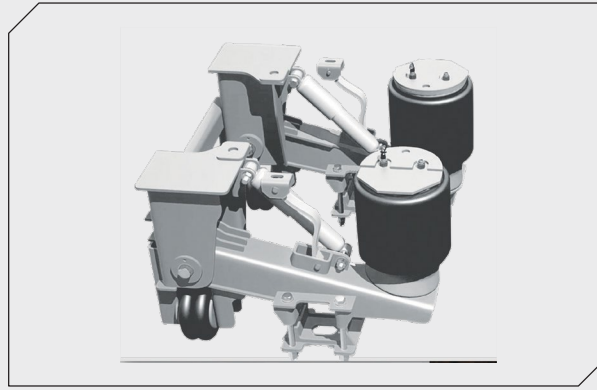

Trailer Air Suspension



Lift Axle

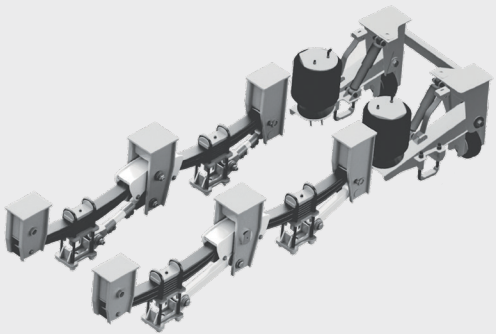

Trailer Mechanical and Air Suspension with Lift Axle

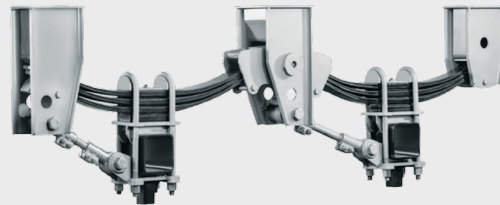

Trailer Mechanical Suspension

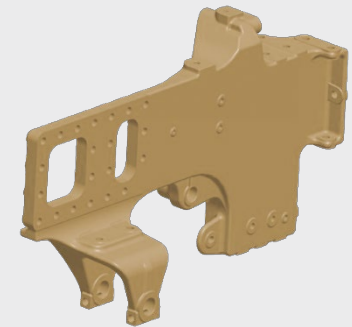

NODO Bracket



# JAI's Product Portfolio – New Launches



## Agriculture Implements



Fertilizer Broadcaster



Fertilizer Broadcaster



Laser Land Leveller



Rotavator



Cultivator

# After Market India JAI's Product Portfolio

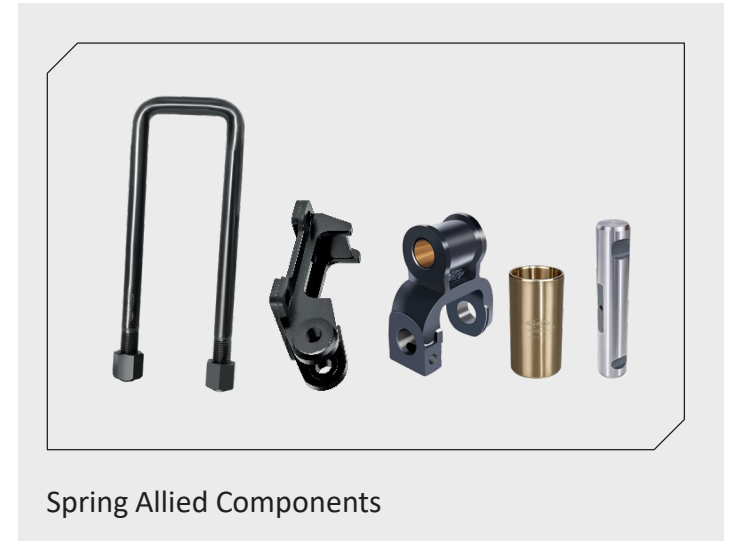
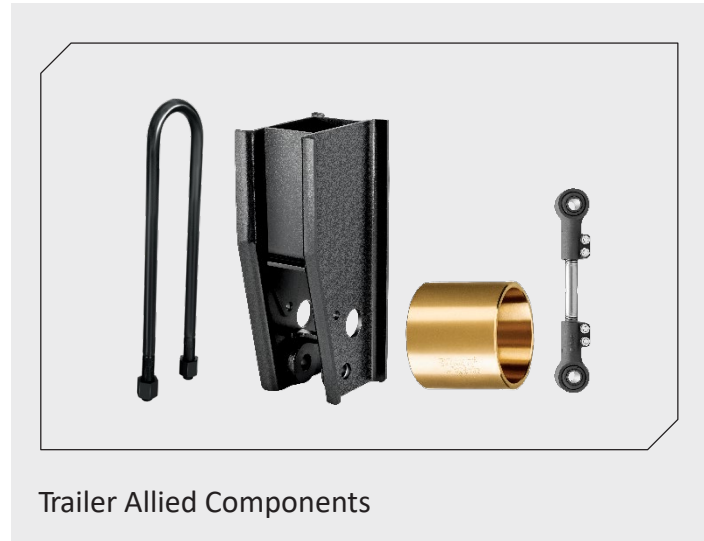
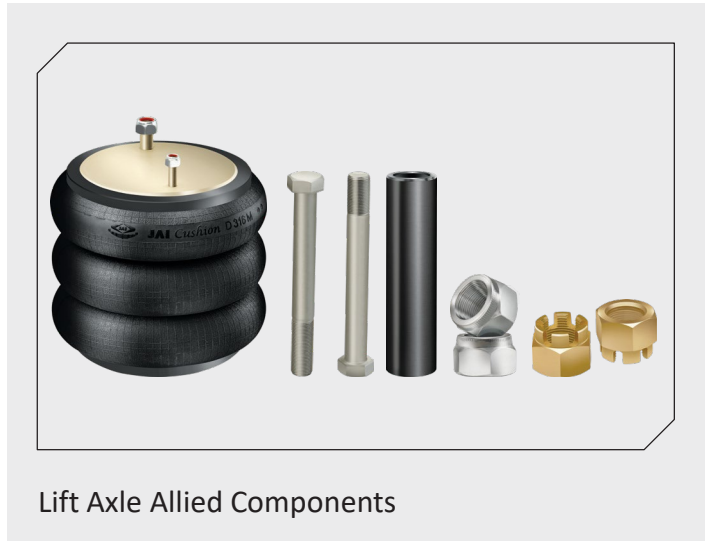

# After Market India JAI's Product Portfolio



Brake lining

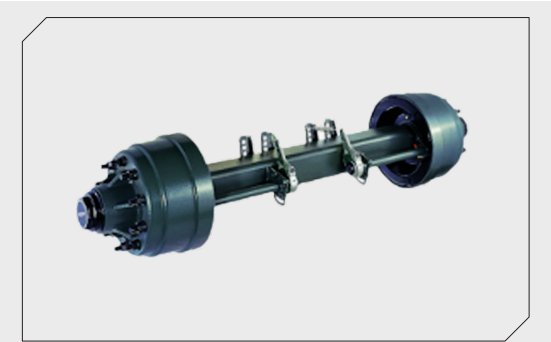

Trailer Axle



Water Pump



Clutch

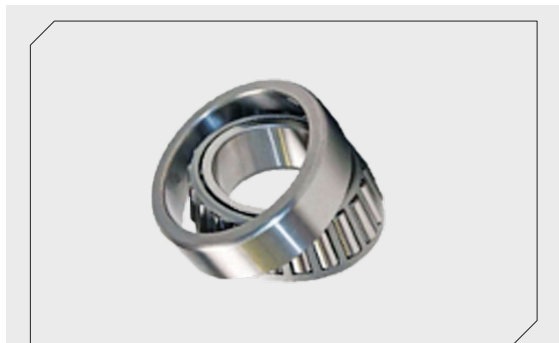

Bearing

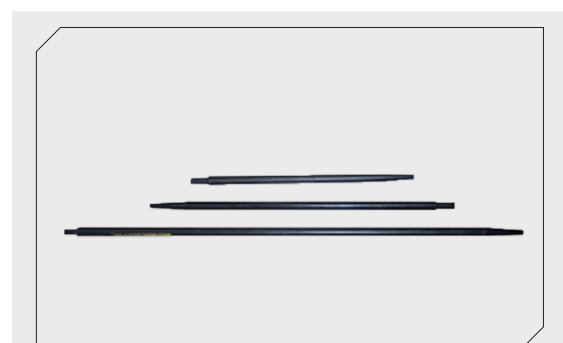

Jack Rod

**Most of the products above are only traded**

Jamna Auto Industries Limited ('JAI')

# OEM-Increasing Content Per Vehicle



## Upcoming products

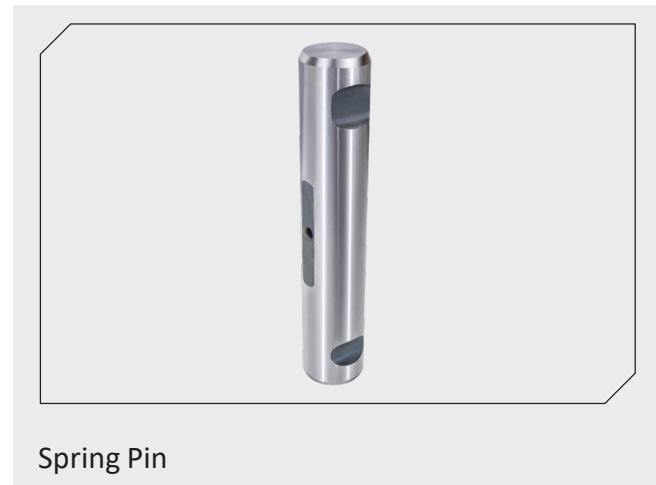
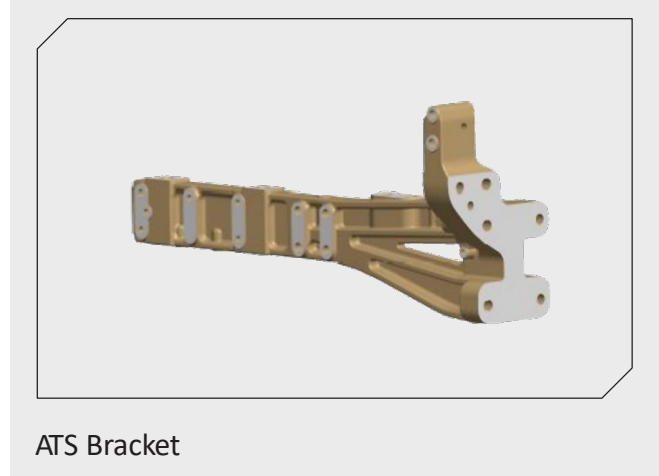

# Shareholding Pattern as on 30<sup>th</sup> September 2023

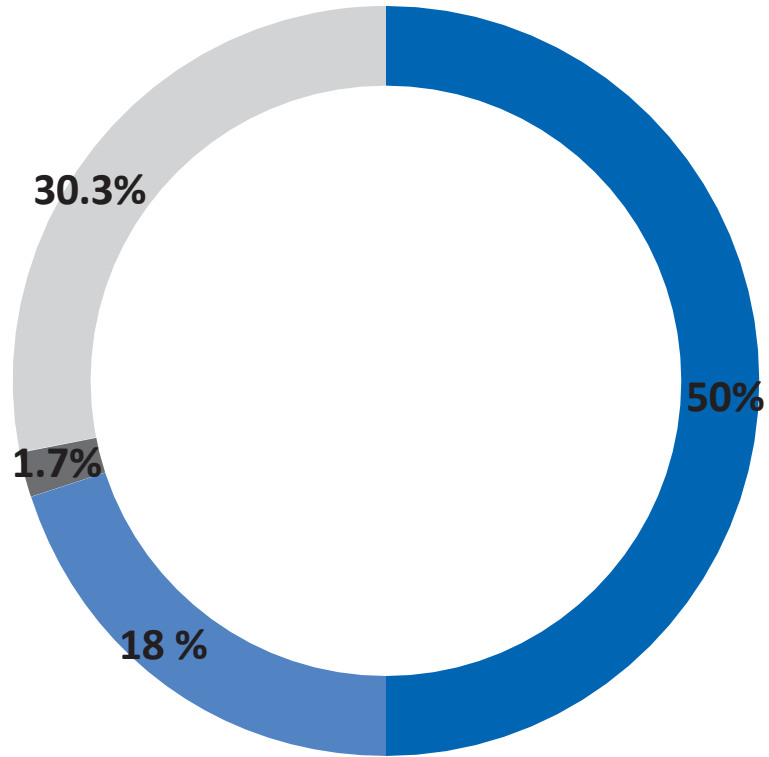

- Promoters
- Institutional investors

Categories	% Holding as on 30.9.2023	% Holding as on 30.6.2023
Promoters	50%	50%
Institutional Investors	18 %	17.9%
Bodies Corporate	1.7%	1.9%
Individual & Others	30.3%	30.2%
Total	100%	100%

# Contributing to the Society



We are committed to contribute to the social and economic welfare of communities in which we operate. Playing an active role in sustaining positive change within society, we aim to create opportunities for the holistic development of people from all sections of society.



Conducting training on compost making for rural women in village Tajewala.ovt. school, Yamuna Nagar



Renovated toilets for girl's students in Govt. Girls College, Gurgaon



Trainee of Jamna Archery Academy awarded in Khelo Jharkhand Programme



Awarding inmates on occasion of Independence Day in District Prison, Faridabad



# Contributing to the Society



## Environment

- Planted & distributed 7840 saplings by involving beneficiaries all over locations in rainy season.
- Distributed 1600 jute & cloth bags to community people in Yamuna Nagar & Pillaipakkam.
- Produced 2000 kg vermi-compost in Yamuna Nagar & Jamshedpur.
- Stated recycling bio waste into compost in 03 Govt. schools in District Yamuna Nagar and trained the sub-staff for making of compost.



## Education

- Awarded 31 meritorious students by in Govt. schools by gifting laptop, smart phones & bicycles in District Yamuna Nagar.
- Provided electricals, Almira, music equipment, water coolers and RO etc. in 04 Govt. schools and an orphanage home in Faridabad, Yamuna Nagar and Gurgaon.
- Repaired and renovated 02 common girl's toilets in Govt. Girls College, Gurgaon & repaired building roof in a Govt. school, Yamuna Nagar.
- 2750 dental kits were distributed to Govt. school students in Yamuna Nagar & Jamshedpur.



## Sports

- Sponsored monthly diet money to 06 sportspersons in GNK College, Yamuna Nagar.
- Signed MoU at Jamshedpur with bodybuilder Mr. Shailesh Kumar for sponsorship of his diet and training for next one year.
- Our sponsored sportsperson Mr. Ashok Soren won Gold in District Archery Championship-2023 in Jamshedpur.
- 05 trainees of Jamna Archery Academy were awarded in Khelo Jharkhand Program 2023-24
- Organized Annual Sports meet in Govt. school and provided sports equipment in Chennai



## Community Reach

- Screened 775 people in 04 Health Check-up Camps in adopted villages, distributed medicines & 180 spectacles to needy patients in Yamuna Nagar & Malanpur.
- Organized awareness cum counselling sessions & distributed 5250 sanitary pads to women & girls in 05 adopted village in Yamuna Nagar & Govt. Girls college, Gurgaon.
- Constructed 20 toilets for BPL/EWS families in Kalesar village under the Open Defecation Free Yamuna Nagar campaign.
- Awarded certificate to 170 sewing trainees who have completed stitching & tailoring course in Yamuna Nagar. Also started 02 new sewing centers and enrolled 245 trainees.
- Started "Anemia Free Yamuna Nagar Campaign" and distributed monthly nutritional food kit to 68 anemic women & girls in Yamuna Nagar & Chennai. Also organized blood testing camps by FPAI in Govt. schools and screened 800 adolescent girls.



**Thank You**

---