



Jamna Auto Industries Limited

Investor Presentation

Q1 FY 23-24



This presentation and the accompanying slides (the “Presentation”), have been prepared by Jamna Auto Industries Limited (the “Company”), have been prepared solely for information purposes and do not constitute any offer, recommendation or invitation to purchase or subscribe for any securities, and shall not form the basis or be relied on in connection with any contract or binding commitment whatsoever. No offering of securities of the Company will be made except by means of a statutory offering document containing detailed information about the Company.

This Presentation has been prepared by the Company based on information and data which the Company considers reliable, but the Company makes no representation or warranty, express or implied, whatsoever, and no reliance shall be placed on, the truth, accuracy, completeness, fairness and reasonableness of the contents of this Presentation. This Presentation may not be all inclusive and may not contain all of the information that you may consider material. Any liability in respect of the contents of, or any omission from, this Presentation is expressly excluded.

Certain matters discussed in this Presentation may contain statements regarding the Company’s market opportunity and business prospects that are individually and collectively forward-looking statements. Such forward-looking statements are not guarantees of future performance and are subject to known and unknown risks, uncertainties and assumptions that are difficult to predict. These risks and uncertainties include, but are not limited to, the performance of the Indian economy and of the economies of various international markets, the performance of the industry in India and world-wide, competition, the company’s ability to successfully implement its strategy, the Company’s future levels of growth and expansion, technological implementation, changes and advancements, changes in revenue, income or cash flows, the Company’s market preferences and its exposure to market risks, as well as other risks. The Company’s actual results, levels of activity, performance or achievements could differ materially and adversely from results expressed in or implied by this Presentation. The Company assumes no obligation to update any forward-looking information contained in this Presentation. Any forward-looking statements and projections made by third parties included in this Presentation are not adopted by the Company and the Company is not responsible for such third party statements and projections.



Q1 FY 23-24
Financial Updates

Financial Trends - QoQ



All figures are in INR crores

	Q1 FY 23-24	Q4 FY 22-23	Q1 FY 22-23
NET SALES	575	634	548
EBITDA	74/13%	82/13%	62/11.2%
PBT	63/11%	71/11.2%	51/9.3%
CASH ACCRUALS	57	63	48

Cash Accruals: PAT+ Depreciation

Profit & Loss Statement



Consolidated QoQ

All figures are in INR crores

Particulars	Q1 FY 23-24	Q4 FY 22-23	QoQ	Q1 FY 22-23	YoY
Net Sales	575	634	-9%	548	5%
EBITDA	74	82	-9%	62	21%
PBT	63	71	-11%	51	24%
PAT	46	52	-13%	37	22%

Revenue Mix



Product Mix

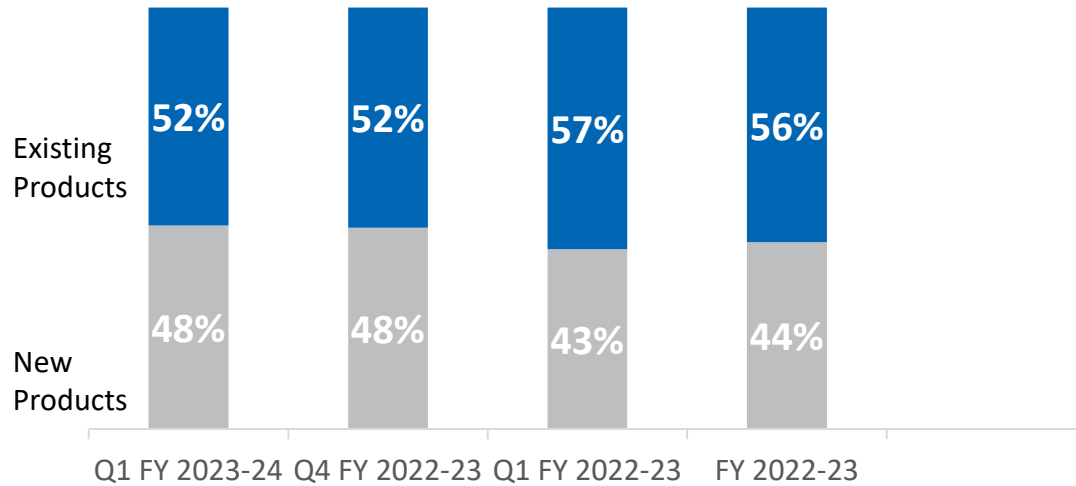

Lakshya Target: **50%** revenue from New Products by FY 2026-27

Market Mix

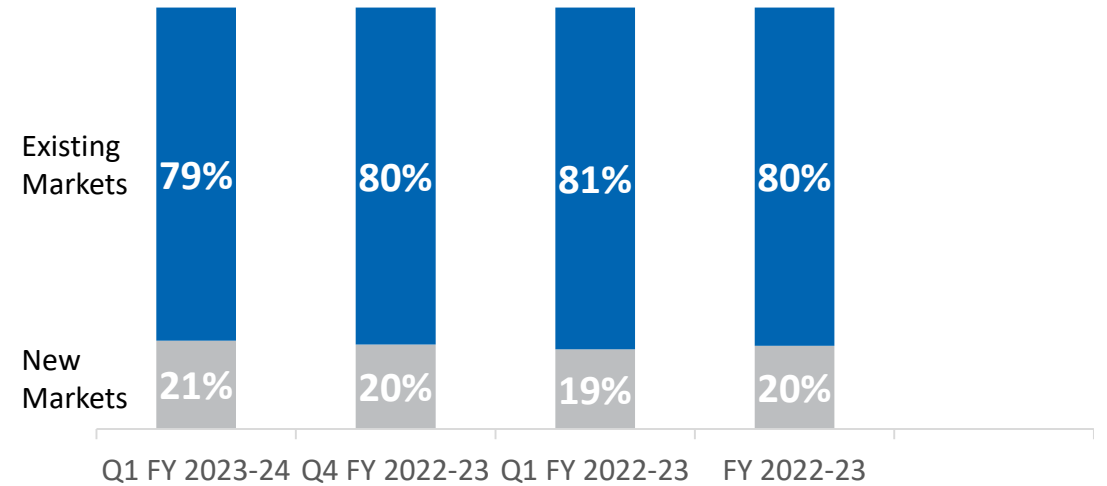

Lakshya Target: **50%** revenue from New Markets by FY 2026-27



Industry Highlights

Industry Highlights



All figures are in '000

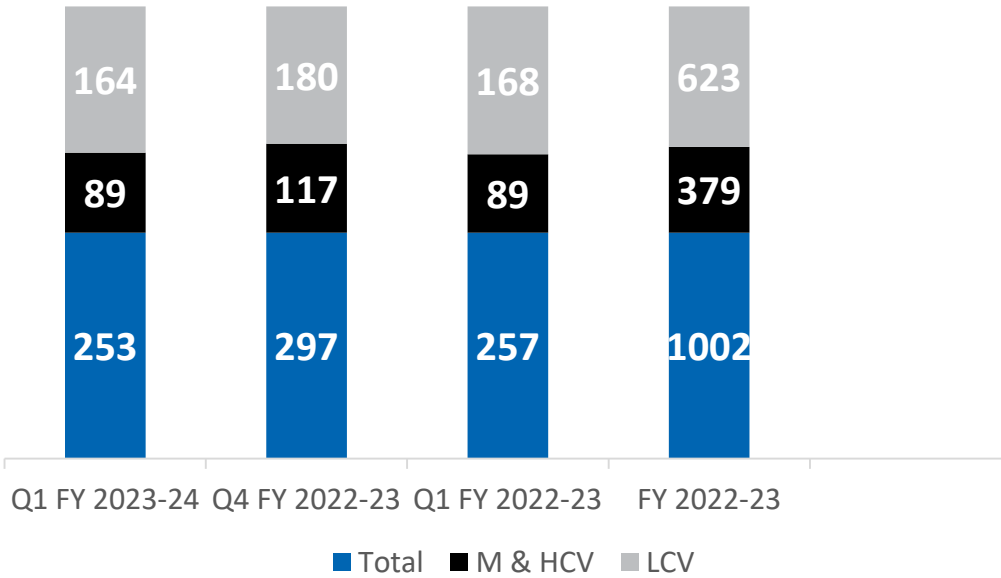

Data Source-SIAM

CV production changes

- ↓ - Q1 FY24 vs Q4 FY23 -15% (Decrease)
- ↓ - Q1 FY24 vs Q1 FY23 - 2% (Decrease)

M&HCV production changes

- ↓ - Q1 FY24 vs Q4 FY23 - 23%(Decrease)
- Q1 FY24 vs Q1 FY23 - 0%(No change)

For the Quarter

QoQ Change %	YoY Change %
-9%	-3%
-23%	0%
-15%	-2%



Company
Overview

JAI at a Glance



Foundation
JAI is a renowned suspension manufacturer for commercial vehicles.

World class Manufacturing Infrastructure
10 Manufacturing units including 1 In-house R&D center

- More than 16,000 touch points
- JAI Shoppe in Sanjay Gandhi Transport Nagar, Delhi which is one of the largest trucking center in India.

Manufacturing
~300+ OEM parts
~5,000+ AMI parts

Sound Financials
CRISIL A1+/AA-

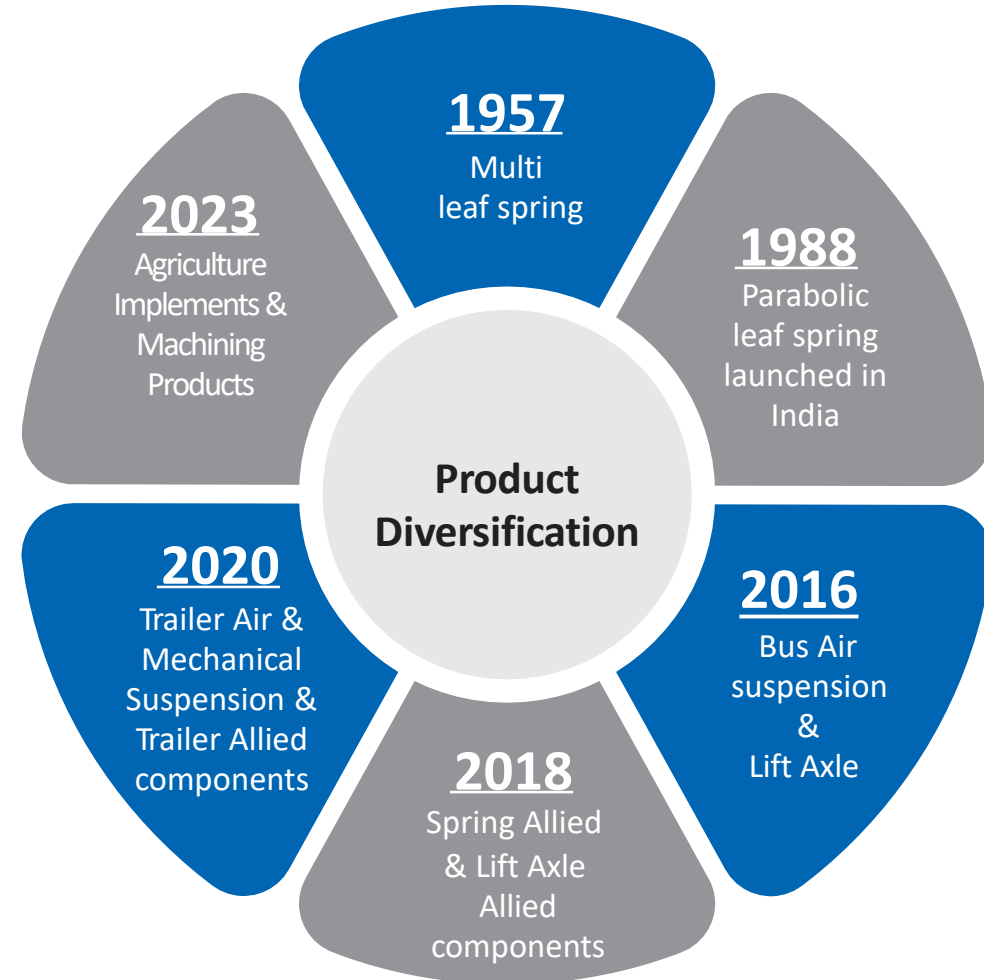

Jai's Plants : Strategically Located Across OEM Plants

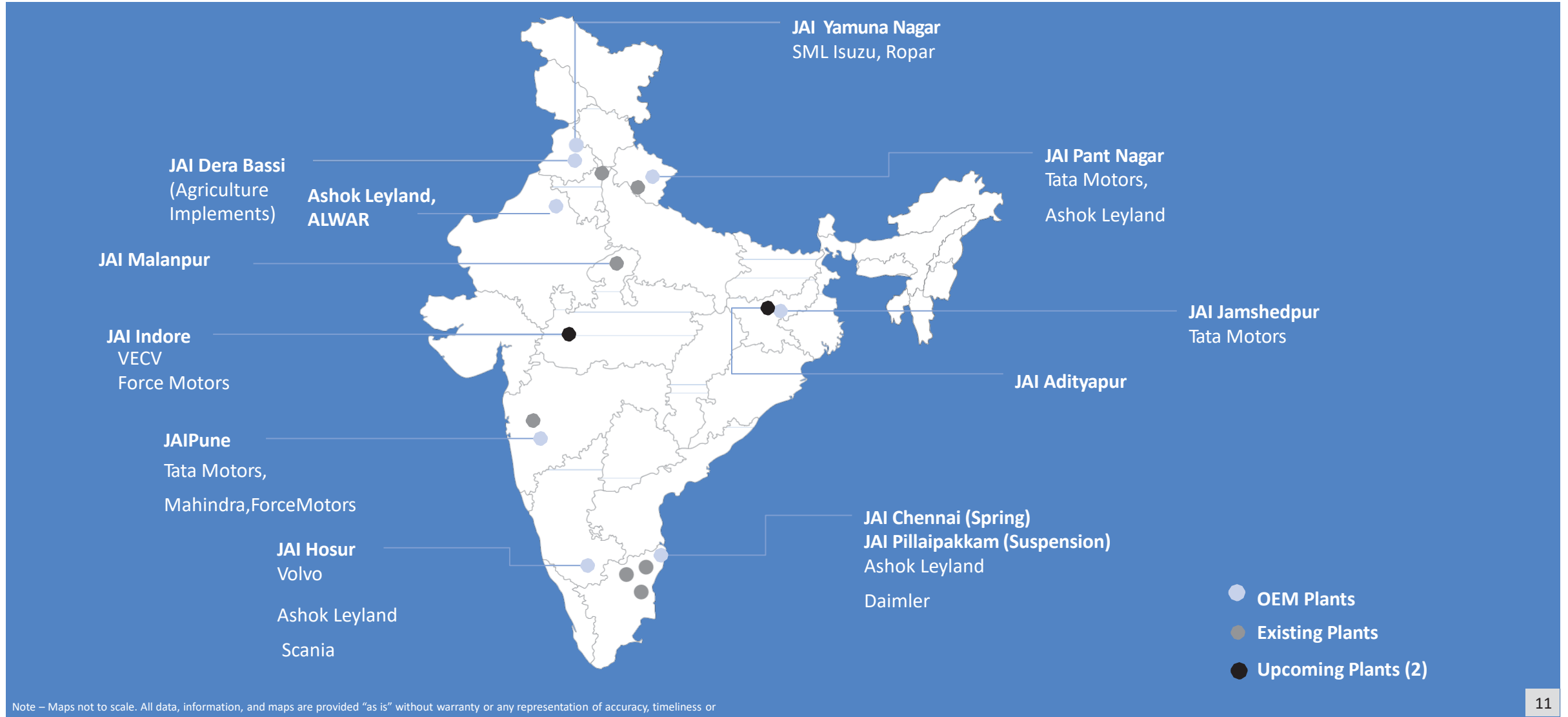

JAI's OEM Customers



JAI's Product Portfolio

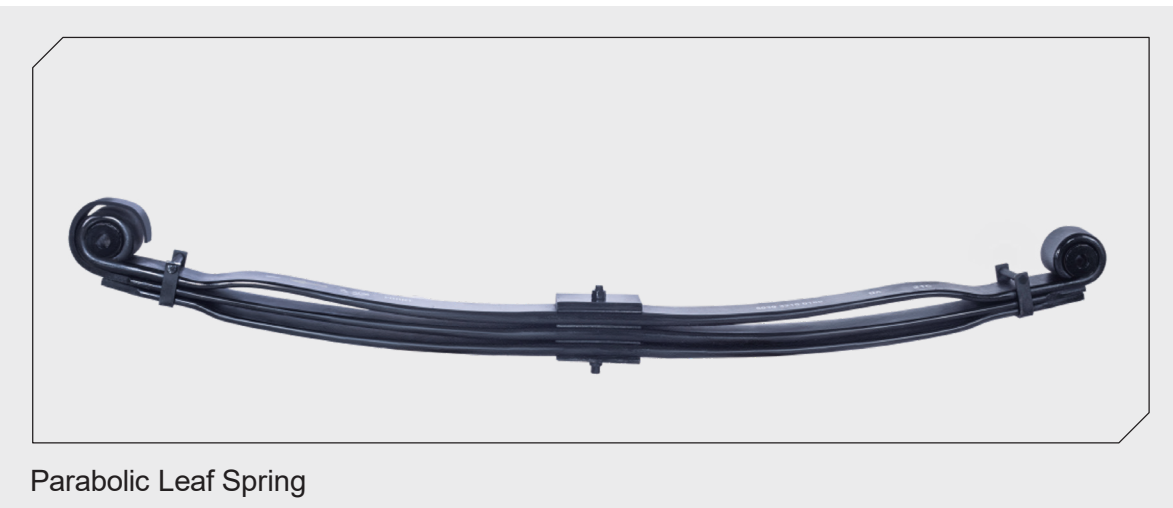
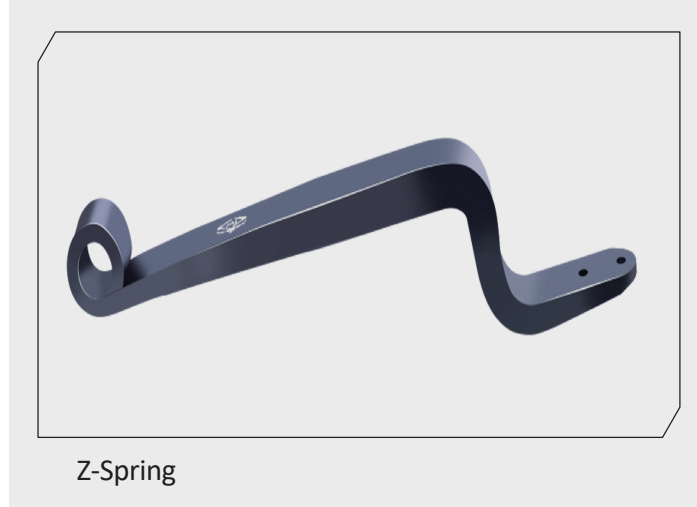
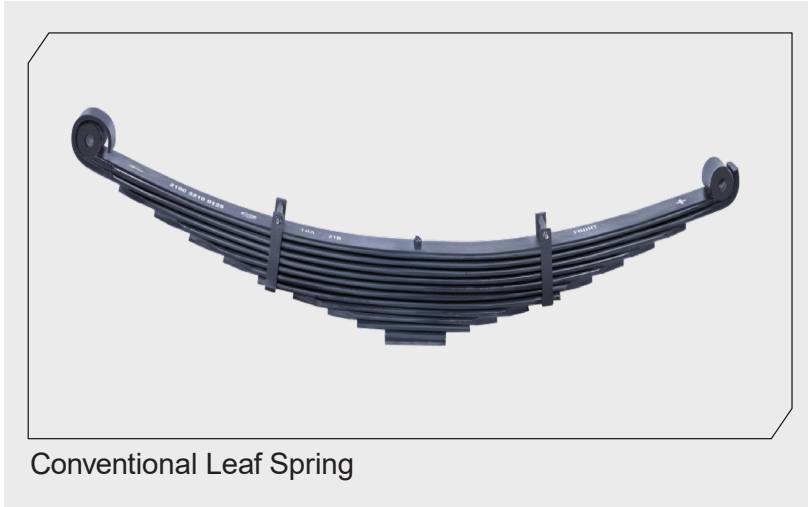

JAI's Product Portfolio



Bus Air Suspension

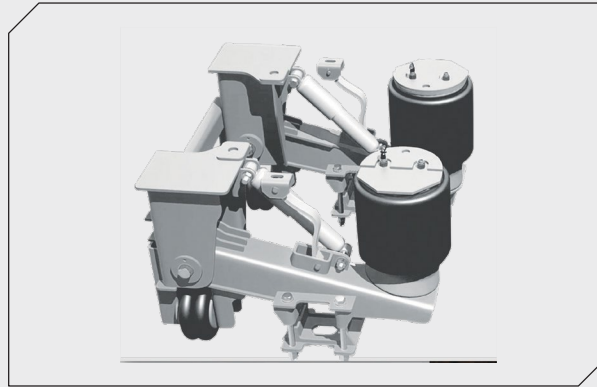

Trailer Air Suspension



Lift Axle

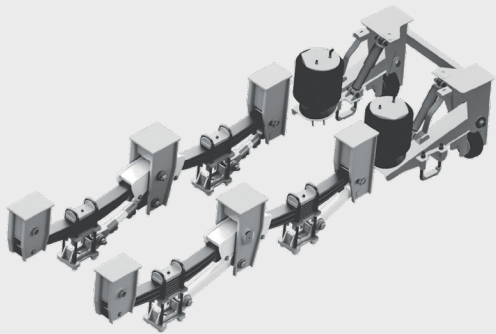

Trailer Mechanical and Air Suspension with Lift Axle

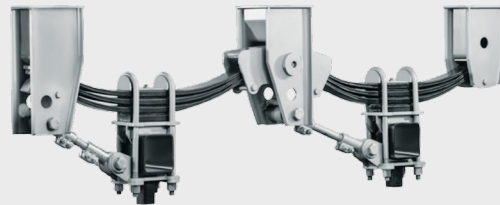

Trailer Mechanical Suspension

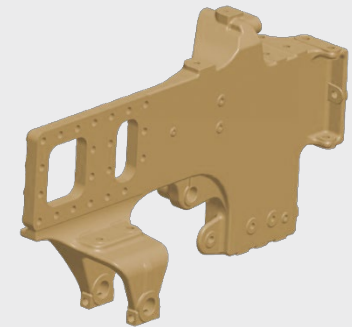

NODO Bracket

JAI's Product Portfolio – New Launches



Agriculture Implements



Fertilizer Broadcaster



Fertilizer Broadcaster



Laser Land Leveller



Rotavator



Cultivator

After Market India JAI's Product Portfolio

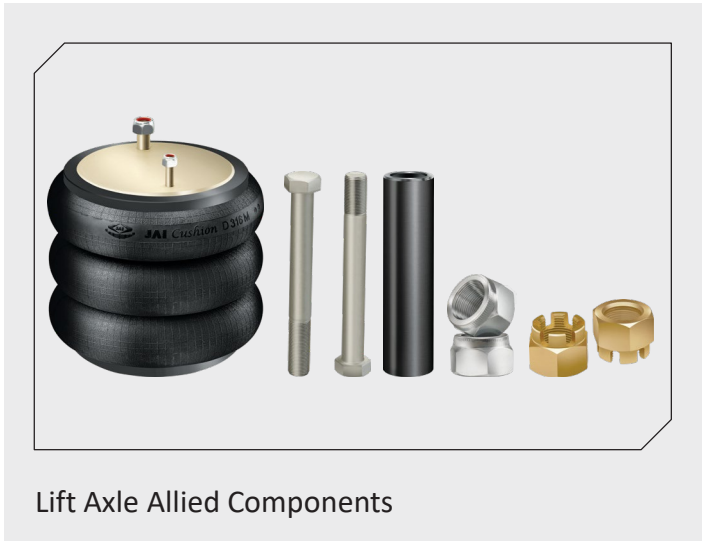

Lift Axle Allied Components

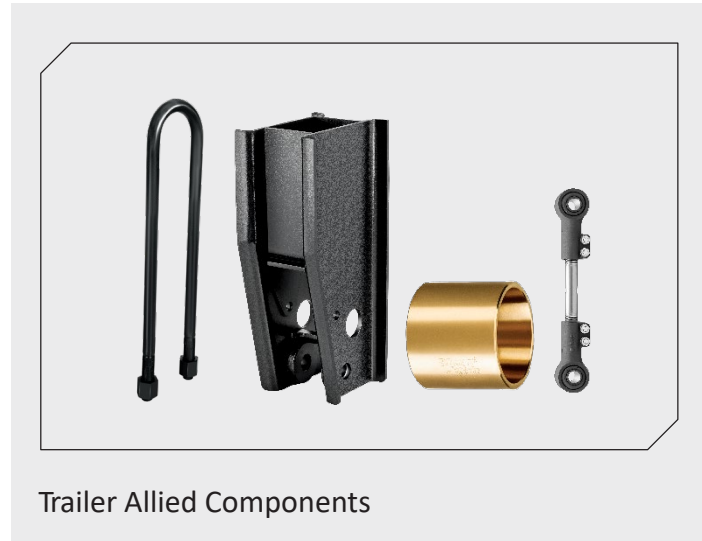

Trailer Allied Components

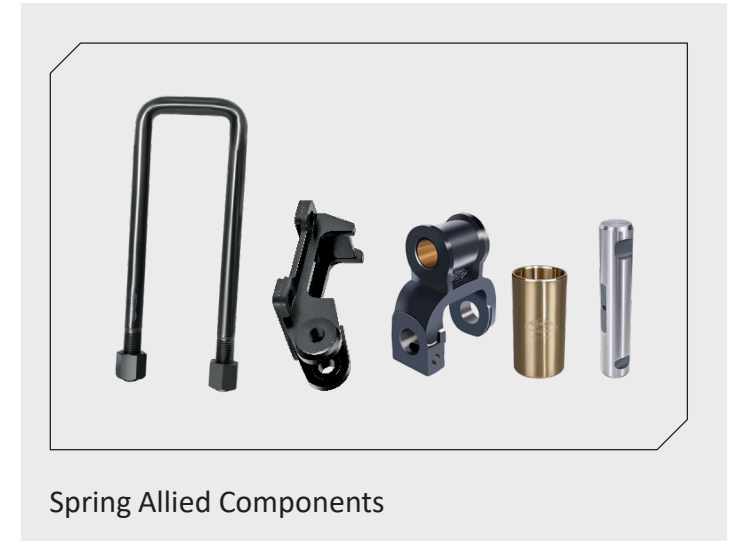

Spring Allied Components

After Market India JAI's Product Portfolio



Brake lining

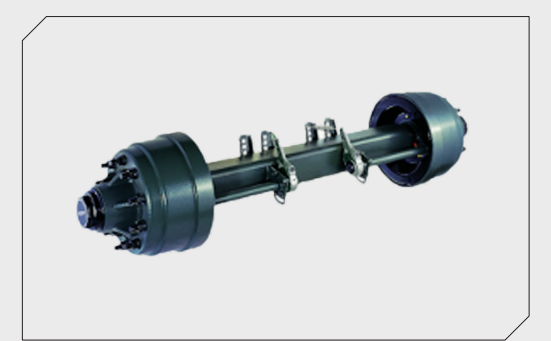

Trailer Axle



Water Pump



Clutch

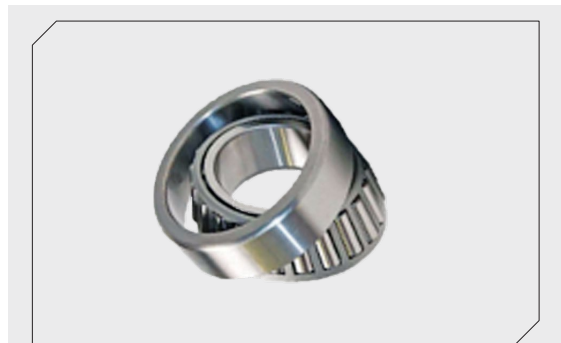

Bearing

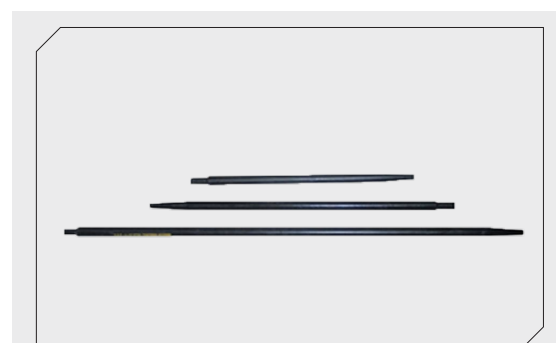

Jack Rod

Most of the products above are only traded

Jamna Auto Industries Limited ('JAI')

OEM-Increasing Content Per Vehicle



Upcoming products

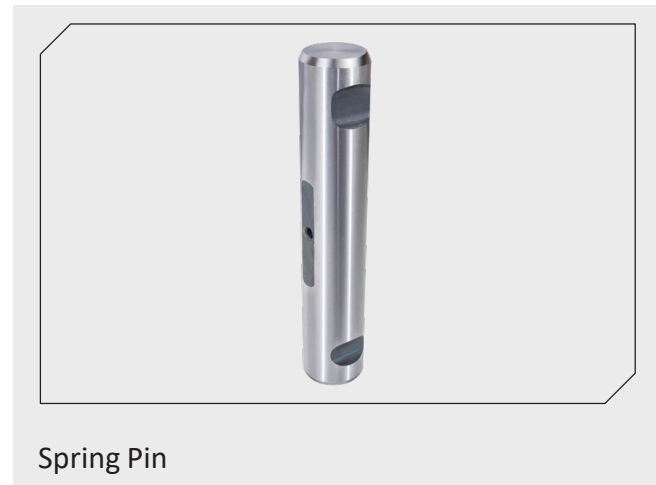
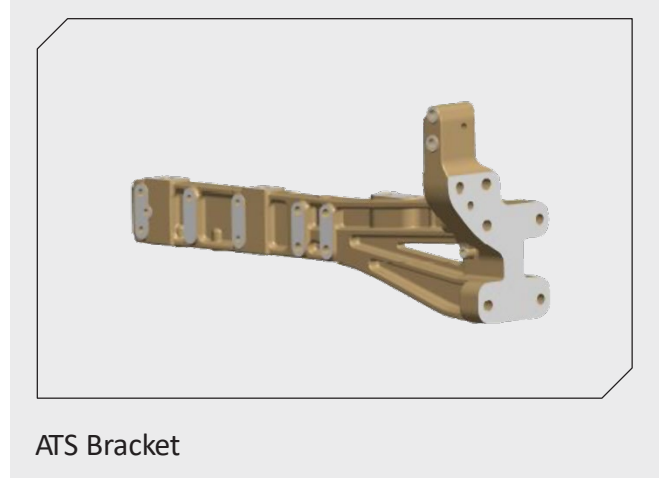

Key Developments for the Q-1



1) Introduced Hybrid leaf Spring in Single Stage Rear Suspension .

2) We are delighted to launch the company's new website with a new and fresh look that perfectly reflects the spirit of our company.

Shareholding Pattern as on 30th June 2023

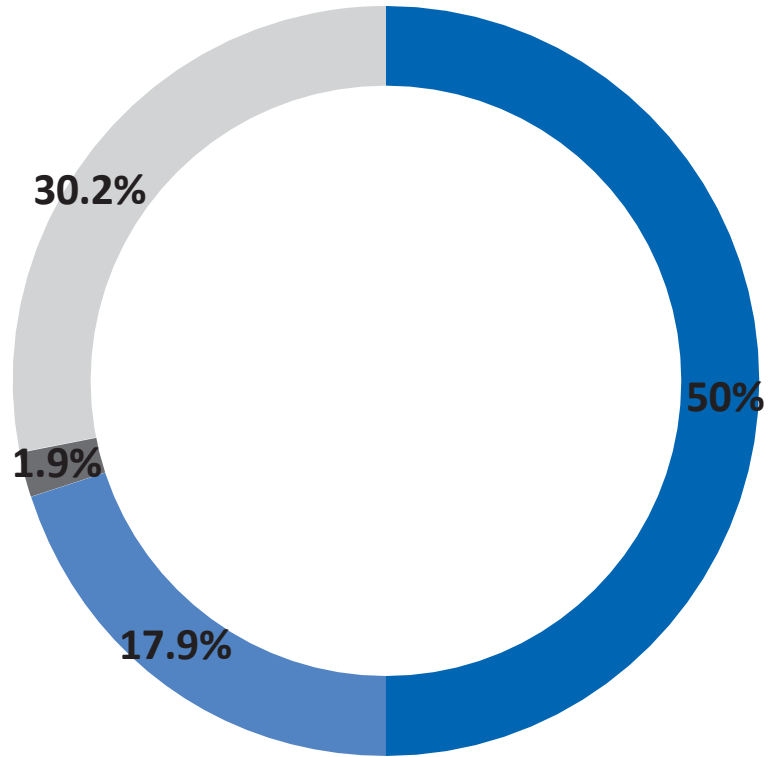

- Promoters
- Institutional investors

Categories	% Holding as on 30.6.2023	% Holding as on 31.3.2023
Promoters	50%	50%
Institutional Investors	17.9%	19.9%
Bodies Corporate	1.9%	1.5%
Individual & Others	30.2%	28.6%
Total	100%	100%

Contributing to the Society



We are committed to contribute to the social and economic welfare of communities in which we operate. Playing an active role in sustaining positive change within society, we aim to create opportunities for the holistic development of people from all sections of society.



Celebrated World Earth Day & World Environment Day all over locations



Renovation of Govt. Primary School's building in Pant Nagar



Our sponsored Bodybuilder Ankur Sharma won Gold in North India Championship-2023



Celebrated World No Tobacco Day all over locations



Contributing to the Society



Environment

- Planted 1050 saplings on the occasion of World Earth Day & World Environment Day all over locations.
- Distributed 2531 jute bags to community people, factory workers and Govt. school students, On the occasion of World Earth Day.
- Organized a cleanliness drive in surrounding area of Malanpur plant & nearby village by involving above 80 Govt. school students and community people



Education

- Renovated school building by repairing of roof, walls and flooring. Doors and window, electricity fitting etc. in Govt. Primary school, Pattarchata in Rudrapur District, Uttrakhand.
- Organized 08 Dental Check-up Camps and 3150 dental kits were distributed to Govt. school student in Yamuna Nagar, in collaboration with Govt. CHC.
- Constructed a drinking water tank for students in Madrsha, Faizpur, Yamuna Nagar.
- Scholarship to 02 fatherless children in Chennai
- Screened 514 girl students during Health Check-Up camp in GNK College, Yamuna Nagar. Total 21 girls were found anemic and providing nutrition kits to them for next three months



Sports

- Sponsored monthly diet to 06 sportspersons in GNK College in Yamuna Nagar
- Sponsored **Jail Premier League-2023** in District Jail, Yamuna Nagar & Central Jail, Ambala by providing 04 cricket kits and 60 dress for inmates.
- Key achievement of our sponsored sportsperson:-
 - Ms Gifita Angelin won Gold in International OKINAWA Goju Ryu Ipoh City karate open championship-2023 in Singapore.
 - Mr. Ankur Sharma won Gold in North India Bodybuilding Championship-23.
 - Ms. Babanpreet Kaur won Gold in 100 Mts at 2nd CPSFI National Athletics Championship- 2023 in New Delhi
 - Mr. Anshul (weightlifter) won Gold in Khelo India University Games-2023 in Noida



Community Reach

- Screened 845 women during 04 gynecology health check-up camp in adopted villages in collaboration with Family Planning Association of India and distributed required medicines
- Distributed 12634 sanitary pads to ensure personal hygiene among rural women in 04 adopted Villages in District Yamuna Nagar
- Over 5000 beneficiaries were sensitized on tobacco hazardous on occasion of World No Tobacco day. Conducted awareness sessions, street play & distributed free pamphlet to create awareness.
- Total 750 women were trained in sewing machine repairing and servicing in 05 villages in District Yamuna Nagar in collaboration with Singer India.





Thank You
