



Jamna Auto Industries Limited

Investor Presentation

Q3 FY 22-23



This presentation and the accompanying slides (the “Presentation”), have been prepared by Jamna Auto Industries Limited (the “Company”), have been prepared solely for information purposes and do not constitute any offer, recommendation or invitation to purchase or subscribe for any securities, and shall not form the basis or be relied on in connection with any contract or binding commitment whatsoever. No offering of securities of the Company will be made except by means of a statutory offering document containing detailed information about the Company.

This Presentation has been prepared by the Company based on information and data which the Company considers reliable, but the Company makes no representation or warranty, express or implied, whatsoever, and no reliance shall be placed on, the truth, accuracy, completeness, fairness and reasonableness of the contents of this Presentation. This Presentation may not be all inclusive and may not contain all of the information that you may consider material. Any liability in respect of the contents of, or any omission from, this Presentation is expressly excluded.

Certain matters discussed in this Presentation may contain statements regarding the Company’s market opportunity and business prospects that are individually and collectively forward-looking statements. Such forward-looking statements are not guarantees of future performance and are subject to known and unknown risks, uncertainties and assumptions that are difficult to predict. These risks and uncertainties include, but are not limited to, the performance of the Indian economy and of the economies of various international markets, the performance of the industry in India and world-wide, competition, the company’s ability to successfully implement its strategy, the Company’s future levels of growth and expansion, technological implementation, changes and advancements, changes in revenue, income or cash flows, the Company’s market preferences and its exposure to market risks, as well as other risks. The Company’s actual results, levels of activity, performance or achievements could differ materially and adversely from results expressed in or implied by this Presentation. The Company assumes no obligation to update any forward-looking information contained in this Presentation. Any forward-looking statements and projections made by third parties included in this Presentation are not adopted by the Company and the Company is not responsible for such third party statements and projections.



Q3 FY 22-23
Financial Updates

Financial Trends - QoQ



All figures are in INR crores

	Q3 FY 22-23	Q2 FY 22-23	Q3 FY 21-22
NET SALES	591	553	445
EBITDA	67/11.3%	63/11.4%	60/13.6%
PBT	56/9.5%	52/9.4%	51/11.5%
CASH ACCRUALS	51	47	46

Cash Accruals: PAT+ Depreciation

Financial Trends - YoY



All figures are in INR crores

	9 Months FY 22-23	9 Months FY 21-22	FY 21-22
NET SALES	1,691	1092	1,718
EBITDA	191/11.3%	143/13.1%	231/13.4%
PBT	159/9.4%	115/10.5%	191/11.1%
CASH ACCRUALS	146	110	178

Cash Accruals: PAT+ Depreciation

Profit & Loss Statement



Consolidated QoQ

All figures are in INR crores

Particulars	Q3 FY 22-23	Q3 FY 21-22	YoY	Q2 FY 22-23	QoQ
Net Sales	591	445	33%	553	6%
EBITDA	66	60	10%	63	6%
PBT	56	51	10%	52	7%
PAT	41	37	10%	37	9%

Profit & Loss Statement



Consolidated YoY

All figures are in INR crores

Particulars	9 Months FY 22-23	9 Months FY 21-22	YoY	12 Months FY 21-22
Net Sales	1,691	1092	55%	1,718
EBITDA	191	143	34%	231
PBT	159	115	38%	191
PAT	116	84	38%	141

Revenue Mix



Product Mix

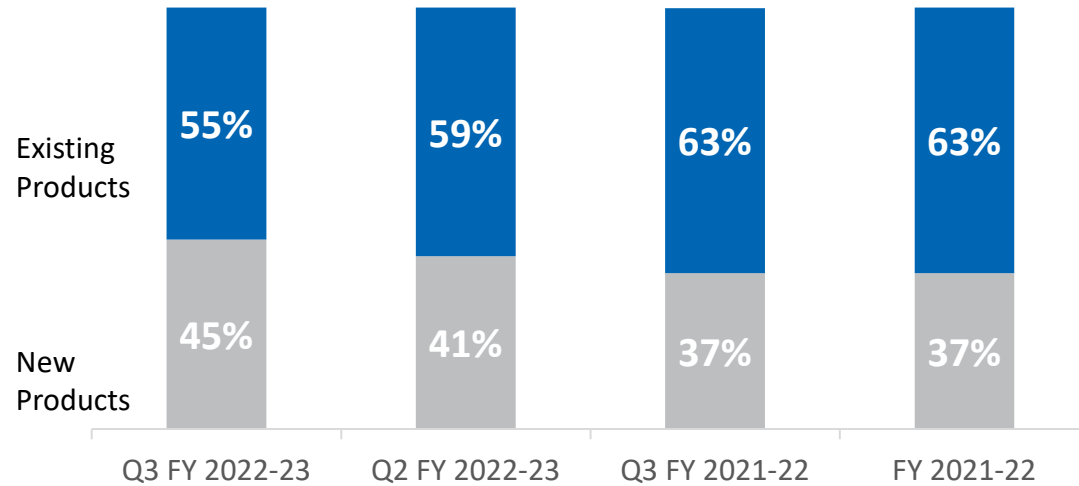

Lakshya Target: **50%** revenue from New Products

Market Mix

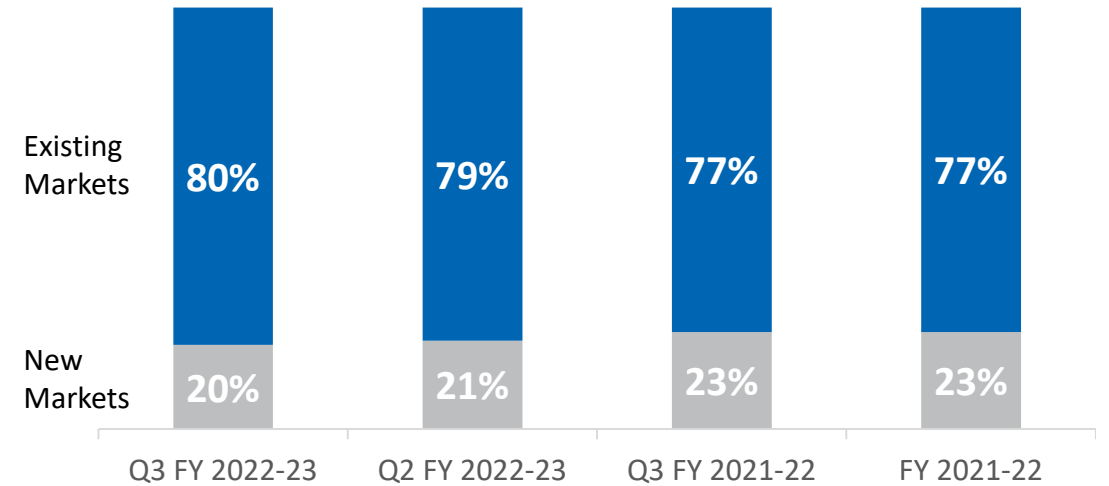

Lakshya Target: **50%** revenue from New Markets



Industry Highlights

Industry Highlights



All figures are in '000

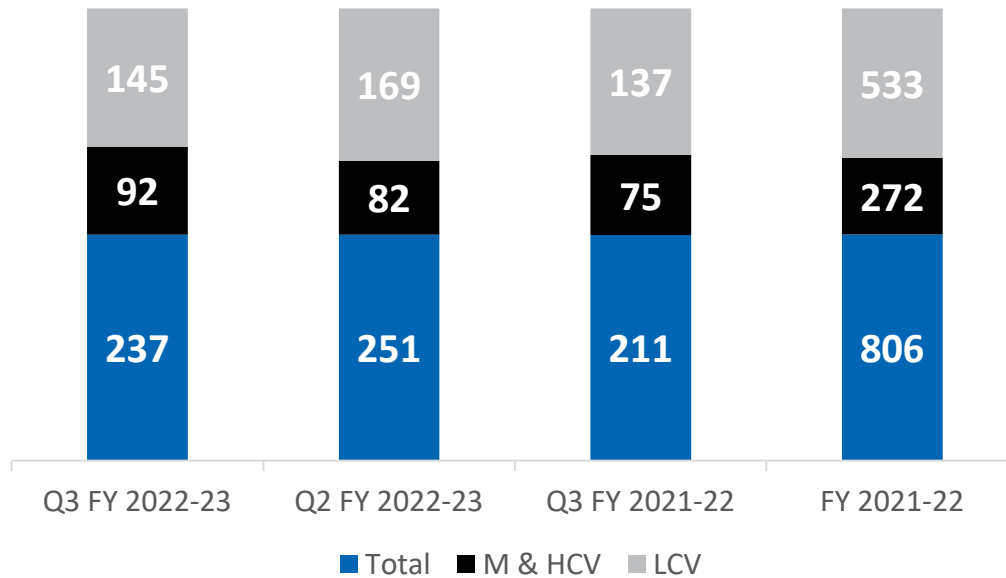

QoQ Change %

YoY Change %

-14%

6%

12%

23%

-6%

12%

Data Source-SIAM

CV production changes

↑ - Q3 FY23 vs Q2 FY23 - (-6%) (Decrease)

↑ - Q3 FY23 vs Q3 FY22 - 12% Increase

M&HCV production changes

↓ - Q3 FY23 vs Q2 FY23 - 12% Increase

↑ - Q3 FY23 vs Q3 FY22 - 23% Increase



Company
Overview

JAI at a Glance



Foundation
JAI is a renowned suspension manufacturer for commercial vehicles.

World class Manufacturing Infrastructure
8 Manufacturing units including 1 In-house R&D center

- More than 16,000 touch points
- Opened JAI Shoppe in Sanjay Gandhi Transport Nagar, Delhi which is one of the largest trucking center in India.

Manufacturing
~300+ OEM parts
~5,000+ AMI parts

Sound Financials
CRISIL A1+/AA-

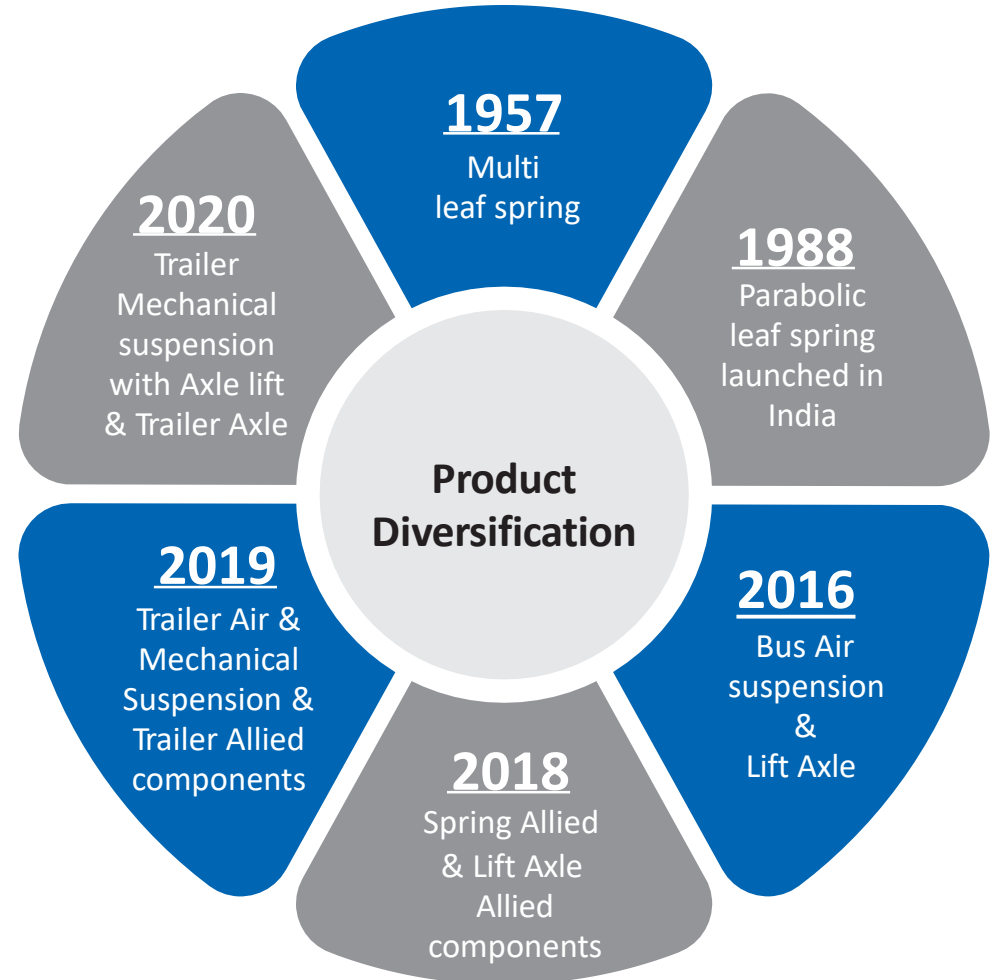

Jai's Plants : Strategically Located Across OEM Plants

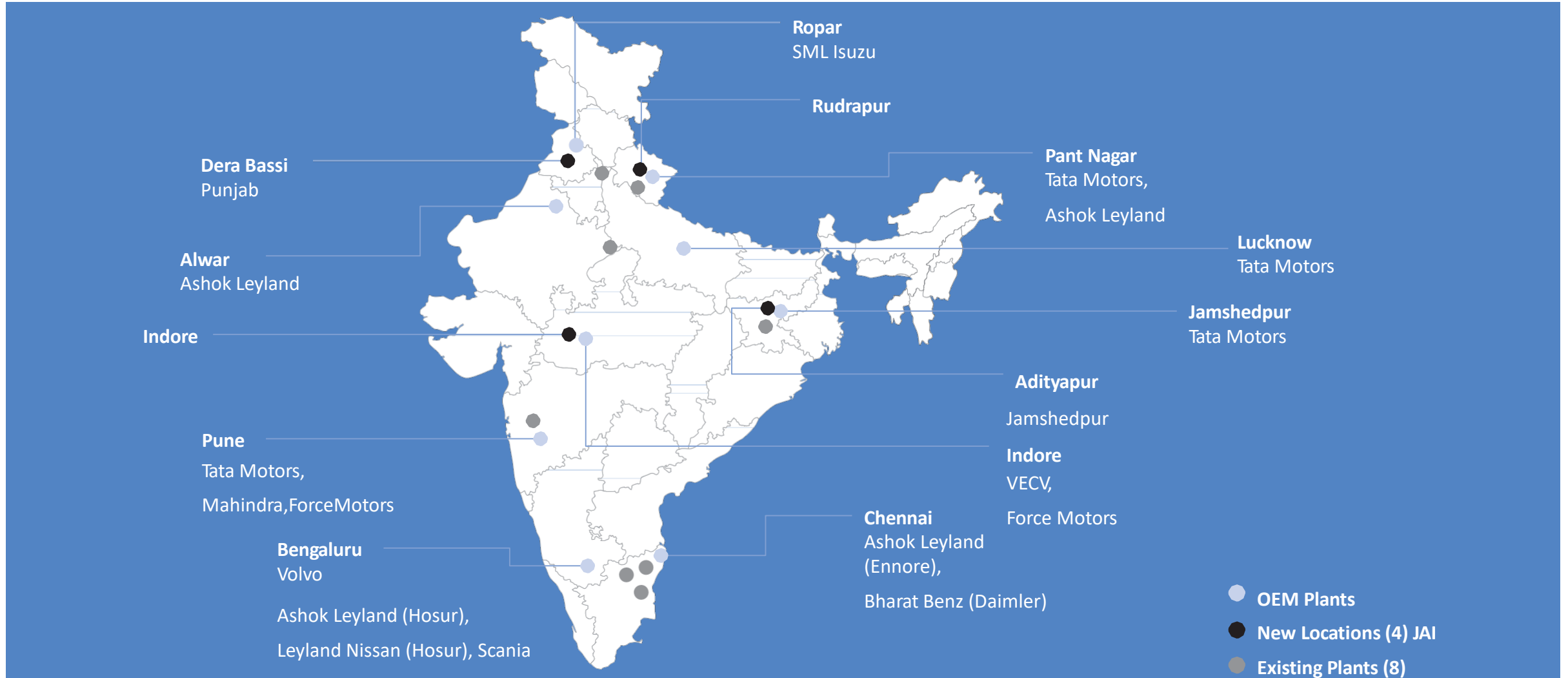

Note – Maps not to scale. All data, information, and maps are provided “as is” without warranty or any representation of accuracy, timeliness or

JAI's OEM Customers



VE COMMERCIAL VEHICLES
A VOLVO GROUP AND EICHER MOTORS JOINT VENTURE

JAI's Product Portfolio

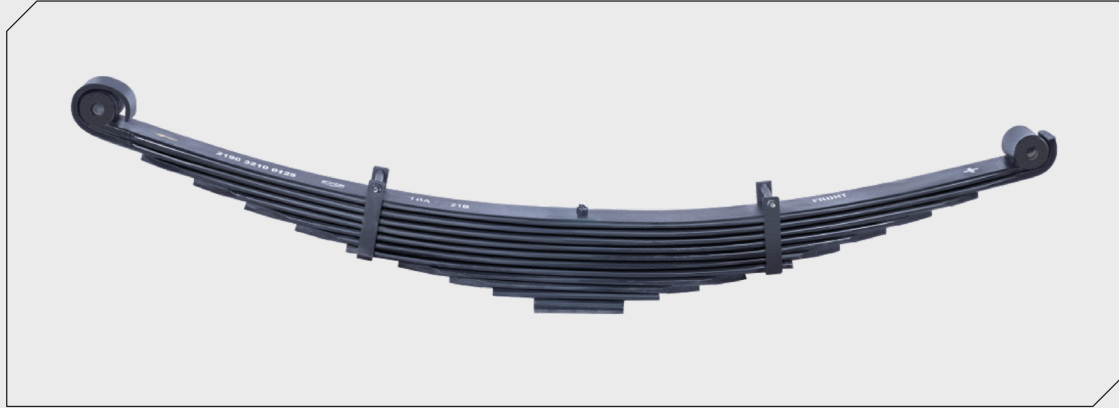

Conventional Leaf Spring



Z-Spring



Parabolic Spring



Stabilizer Bar

JAI's Product Portfolio



Bus Air Suspension

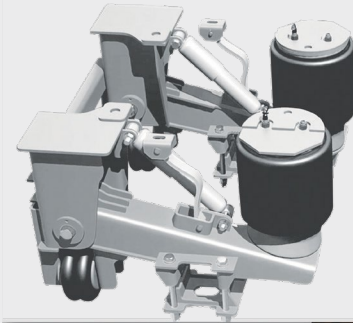

Trailer Air Suspension



Lift Axle

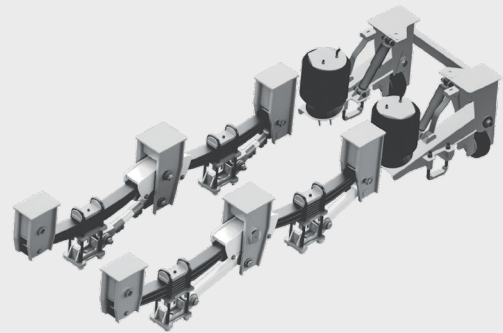

Trailer Mechanical and Air Suspension with Lift Axle

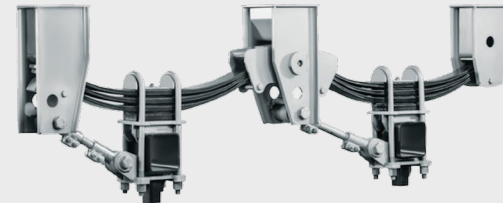

Trailer Mechanical Suspension

After Market India JAI's Product Portfolio

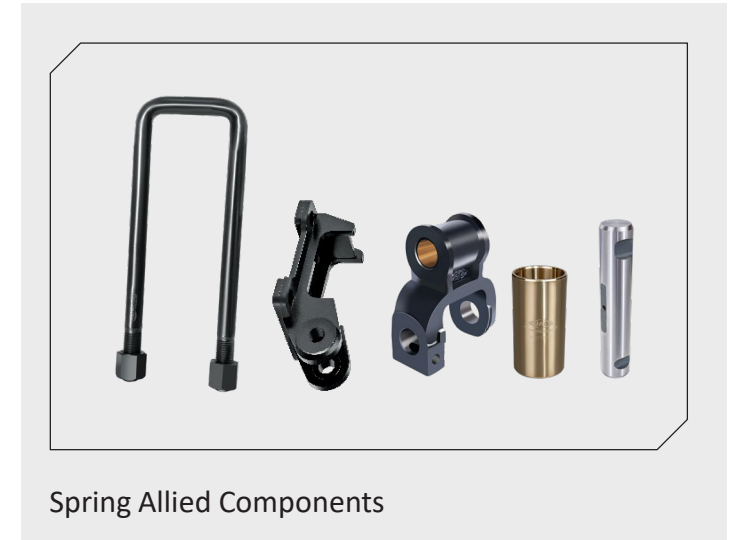
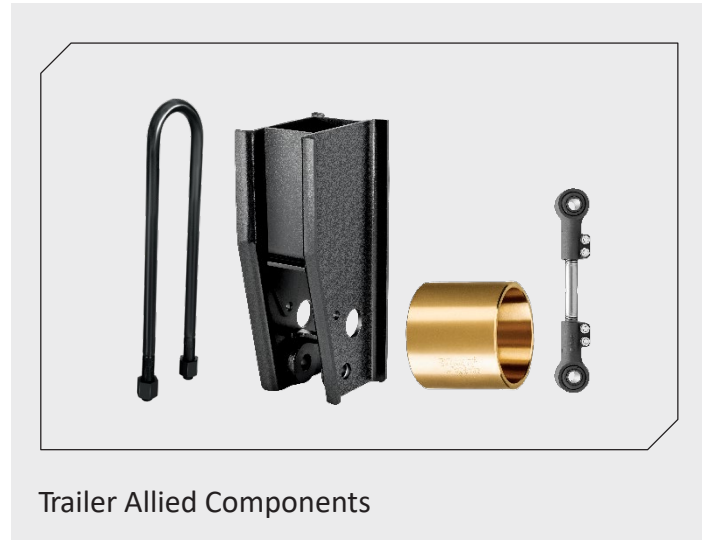
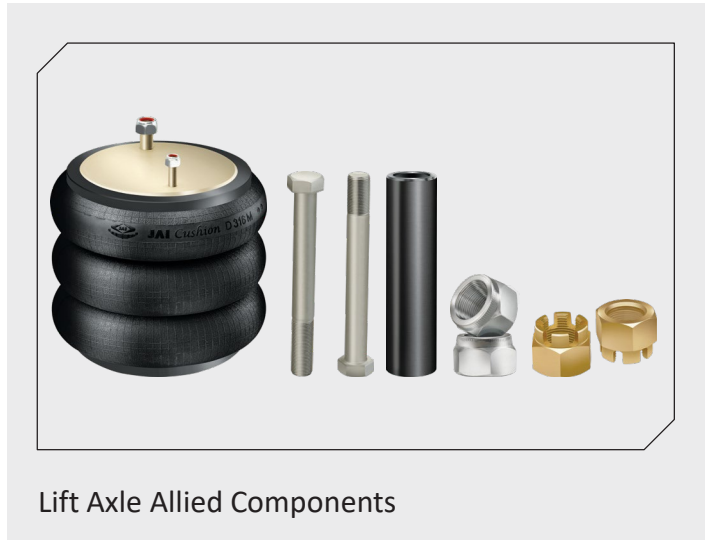
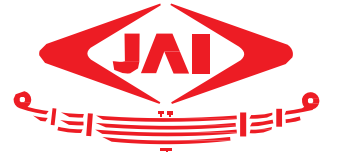

After Market India JAI's Product Portfolio



Brake lining

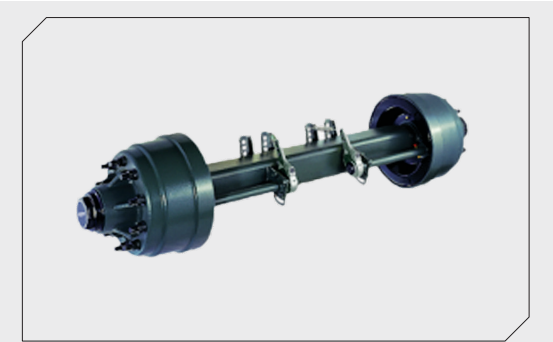

Trailer Axle



Water Pump



Clutch

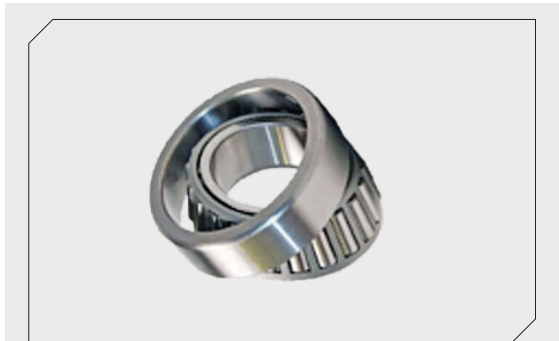

Bearing



Jack Rod



Universal Joint Cross

Most of the products above are only traded

Jamna Auto Industries Limited ('JAI')

OEM-Increasing Content Per Vehicle



Upcoming products

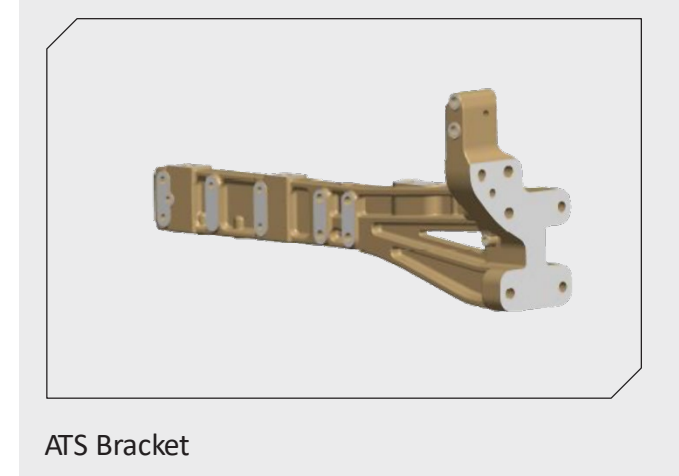
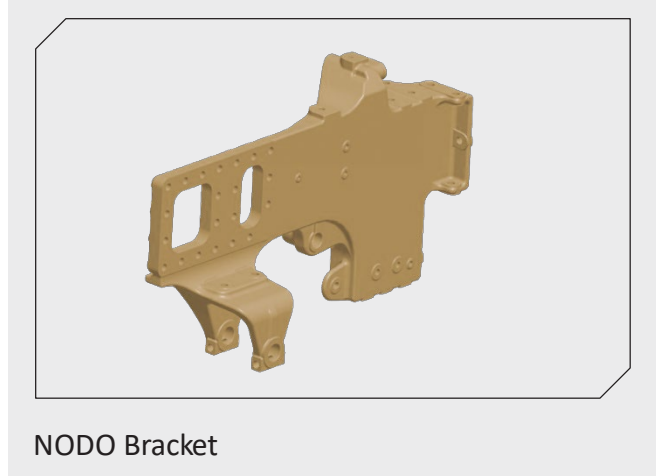

Key Developments for the Q-3



1) Launched special application products in AMI such as springs with factory fitted bushes and heavy duty springs for hilly areas.

2) As a part of digitalization, we have successfully implemented RAMCO ERP in Uttarakhand plant which counts to implementation in total 5 of our plants and after market operations.

JAI participation in 16th Auto Expo 2023 - Components



Shareholding Pattern as on 31st December 2022

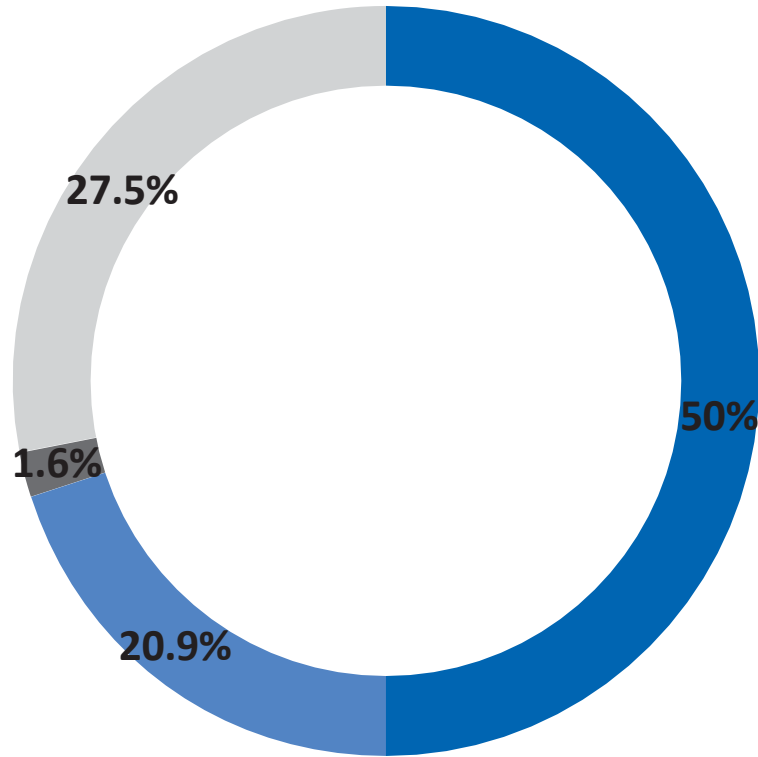

- Promoters
- Institutional investors

Categories	% Holding as on 31.12.2022	% Holding as on 30.9.2022
Promoters	50%	50%
Institutional Investors	20.9%	20.5%
Bodies Corporate	1.6%	1.6%
Individual & Others	27.5%	27.9%
Total	100%	100%

Contributing to the Society



We are committed to contribute to the social and economic welfare of communities in which we operate. Playing an active role in sustaining positive change within society, we aim to create opportunities for the holistic development of people from all sections of society.



Distributed saplings and jute bags to Govt. school students in Chennai



Awarded bicycles, tabs, and smart phones to Govt. school's meritorious students in YNR



Our sponsored wrestler Ms. Manpreet Kaur won bronze in Senior National Wrestling Championship, Visakhapatnam



Distributed blankets to needy people in slum areas of Delhi & NCR



Contributing to the Society



Environment

- Planted 2307 saplings across all plants locations.
- Constructed Vermi Compost Pit & trained 50 inmates on making of vermi compost in District Prison, Panipat.
- Installed 60 twin bins for waste segregation in 10 Govt. schools in YNR.



Education

- Awarded meritorious students by distributing laptop, smart phones and bicycles in Govt. schools of YNR & JSR.
- Awarded annual scholarship to 265 meritorious and deserving college students in YNR.
- Enrolled 122 students for short term job oriented courses in “School of Employability Project, GNKITM campus, YNR.
- 99 Students got placed in various organization, who were completed various short term vocational course through our School of Employability Project in YNR.
- Distributed dental kit amongst 780 school students & sensitized on dental hygiene in JSR.
- Total 190 female including prison inmates passed out 6 months certificate course from Jamna Sewing Training centers in YNR & Panipat



Sports

- Sponsored 18 star sportsperson for diet on monthly basis in YNR & Punjab
- Signed an MoU with Abhinav Bindra Foundation to sponsor athletes preparing for Olympic & Paralympic games in Mohali, Punjab.
- Ms. Pooja Raghav, our sponsored player, won bronze medal in 5th India Open International Taekwondo Championship-2022.



Community Reach

- Total 352 community people were screened during 2 eye check up camps in Yamuna Nagar & Jamshedpur, and distributed 200 free spectacles & medicines to the needy ones
- Gifted Stretcher, Wheel chair & E-rickshaw to Central Jail, Ambala on request.
- Gifted 25 Wheelchairs to District Administration Gurugram for elderly and physically disabled voters to cast their vote during The panchayat Elections.
- Distributed nutrition kits to 366 pregnant women and 87 malnutrition children in 08 adopted villages in YNR, JSR and .H.C Chennai on monthly basis.
- Distributed monthly pension to 118 sr. citizens, widow ladies and PWDs in 05 adopted villages, YNR
- Distribute 815 blankets to migrant labors, poor people and inmates in Ambala, Delhi & NCR



Thank You
