



Jamna Auto Industries Ltd.

Investors' Presentation
Q1 FY'20



Company Overview



Jamna Auto Industries Limited is referred to as "JAI" hereafter

Future ready for growth...

Key Milestones



Started Business

1954



2nd Multi-leaf manufacturing Plant in Malanpur

1991



Acquired Tata's Captive Springs Business in Jamshedpur

2007



Collaboration with Ridewell corporation USA



1957

1st Multi-leaf manufacturing Plant in Yamuna Nagar



1999

3rd Multi-leaf manufacturing Plant in Chennai



2008

4th Multi-leaf manufacturing Plants in Jamshedpur & 5th plant in Pantnagar (Assy)

Assembly line in Hosur

2012



6th & 7th Plant in Pune & Pillaipakkam for Air Suspension and Lift Axle

2016



Technical Collaboration with Tinsley Bridge UK

2018

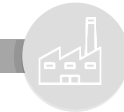

2015

Set up in-house R&D in Pune



2017

8th manufacturing Plant in Hosur & 9th plant in Lucknow (Assy)



“ We are Still going! ”

”

Future ready for growth...

Expand Locations

Manufacturing Plants

- Yamuna Nagar
- Malanpur
- Chennai 1- Leaf Spring
- Chennai 2- Suspension
- Jamshedpur
- Pune
- Hosur

Assembly Plants

- Lucknow*
- Pant Nagar*

Upcoming Plants

- Indore
- Adityapur*

*Under subsidiaries of Jamna

Diversify Products

Existing Products

- **Leaf Spring**
- **Parabolic Spring**
- **Lift Axle**
- **Air Suspension**

Products in the pipeline

- **Stabilizer Bar**
- **U Bolt**
- **Z Springs**
- **Trailer Suspension**

De-risk Markets

Existing Markets

- **OE India**
- **AM India**
- **AM Exports**
- **OE Exports**

Key Strengths

Team of expert, innovative, self driven people

Best in class manufacturing facilities

Largest Supplier to Tata, Leyland & Daimler

Prudent financial management policies

Future ready for growth...

Operational Goals

Financial Goals

Product De-risking

Diversifying Markets

Maximizing Returns

Value Creation

GOALS

33%

Revenue from
New Products

33%

Revenue from
New Market

33%

ROCE

33%

Dividend
Payout

ACHIEVED
FY'19

34%

Revenue from
New Products

16%

Revenue from
New Market

55%

ROCE

33%

Dividend*
Payout

**9th consecutive year of dividend payout*

Future ready for growth...

JAI's OEM Customers



Future ready for growth...

Existing Products

Conventional Leaf Spring



Parabolic Leaf Spring



Lift Axle

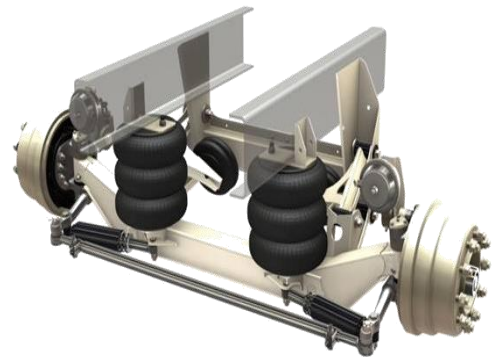

Air Suspension

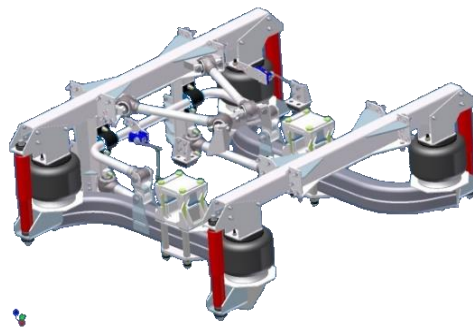

Upcoming Products

Stabilizer Bar



U Bolt



Z Spring



Trailer Suspension

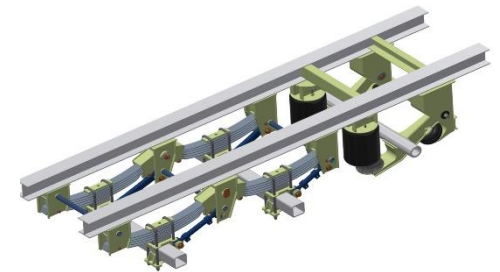

Future ready for growth...

JAI's Plants: Strategically located across CV hubs

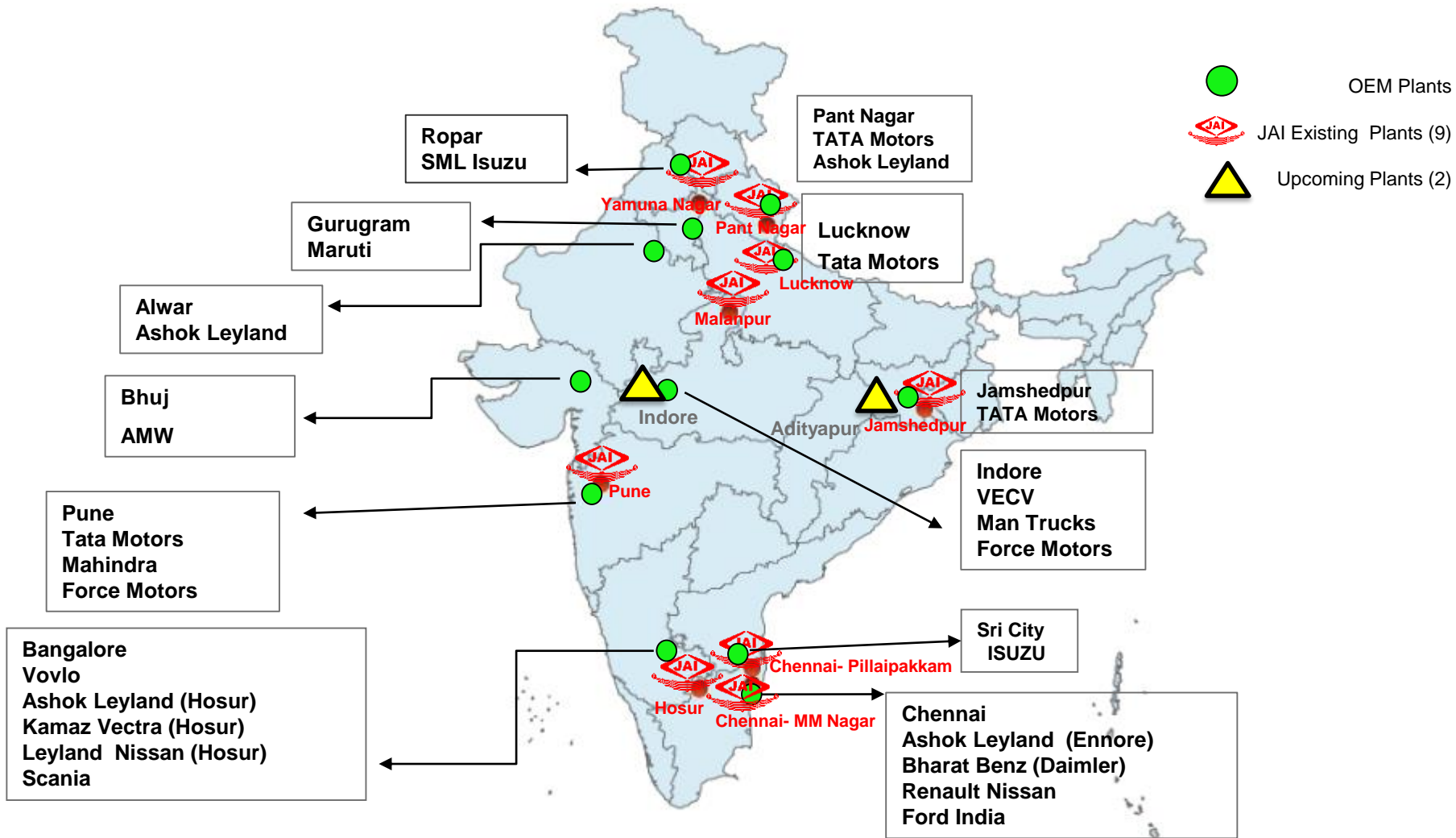

Map Source: as available on www.surveyofindia.gov.in dated 17.02.2017
The Map is for illustrative purpose only

Category Wise Breakup

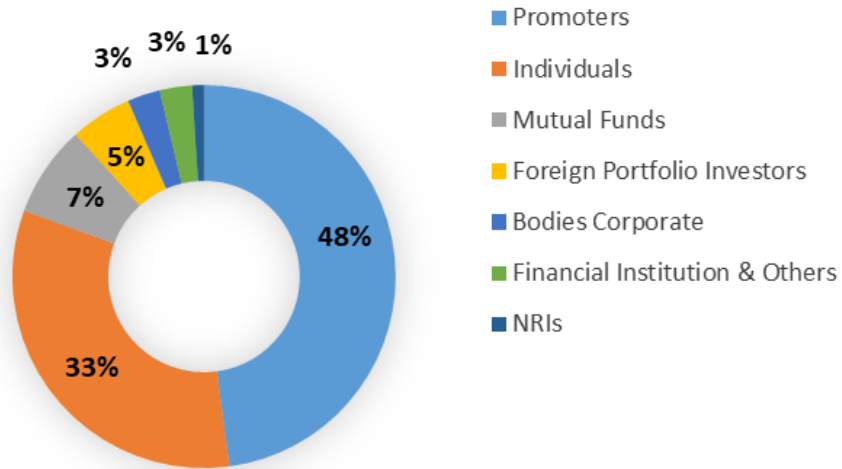

Categories	% Holding
Promoters	48%
Individuals	33%
Mutual Funds	8%
Foreign Portfolio Investors	5%
Bodies Corporate	3%
Financial Institution & Others	3%
NRIs	1%
Total	100%

Industry Highlights

- Indian and Global economic growth sentiment remains subdued, according to World Economic Outlook Update, July 2019
- GDP growth forecast revised downwards by RBI to 6.9% for FY'20 in the August Monetary Policy
- CV Sector impacted by demand slowdown because of higher axle loads, liquidity stress, low freight availability for cargo operators
- CV production declined by 14% in Q1'20 and subdued demand momentum continues to exist and will be impacted by the erratic monsoon season

Decline in the CV Industry

- Total CV production declined by 14% YoY
- M&HCV production saw a decline of 17% YoY

CV Production: Q1'20 vs Q1'19

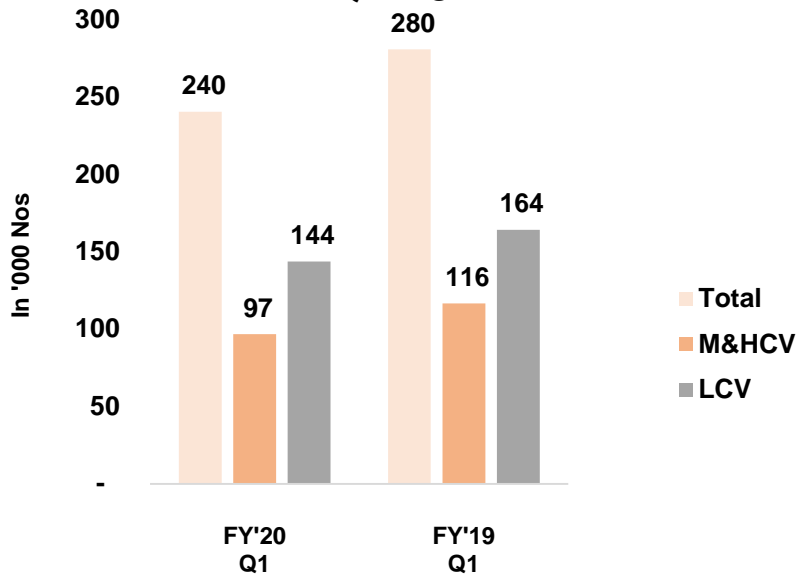

Data Source- SIAM + Internal

JAI improved its market share to 71% for the quarter

Market Share - OEM India

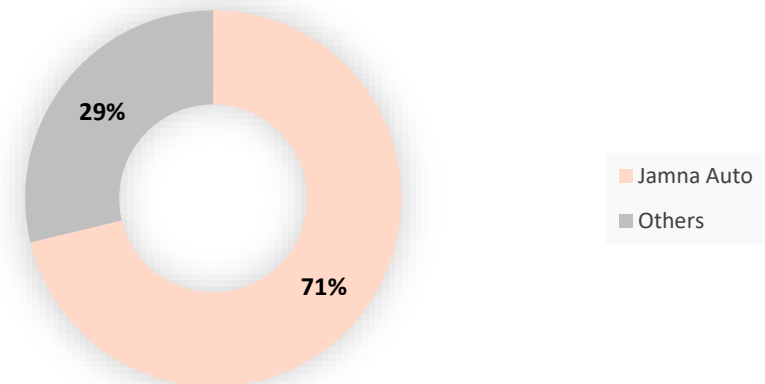

Data Source- Internal

Future ready for growth...

1980's

Leaf Spring Manufacturer	Base Country	Capacity
NHK Spring Co. Ltd	Japan	200,000
Delphi	USA	100,000
Eaton/Oxford	Canada	100,000
Krupp	Germany	40,000
Hendrickson	USA	40,000
DSP	USA	40,000
Rejna	Europe	40,000
Hoesh	Germany	30,000
Sarfedern	Germany	20,000
Johns Woodhead	UK	10,000

JAI has come as the top spring manufacturer of the world for CV Industry

Current

Leaf Spring Manufacturer	Base Country	Capacity
Rassini	Mexico	250,000
Jamna Auto Industries Limited	India	250,000
Hendrickson	Canada & Mexico	216,000
NHK Spring Co. Ltd	Japan & Thailand	150,000
Dong Feng	China	105,000
FAW	China	100,000
MBHA	Spain	60,000
Olgen	Turkey	40,000
LPDN	Europe	26,500

Capacity in Tons per Annum

Financial Updates

Key Financial Trend : Q1 FY'19 Vs. Q1 FY'20



All Figures in Rupees Crore

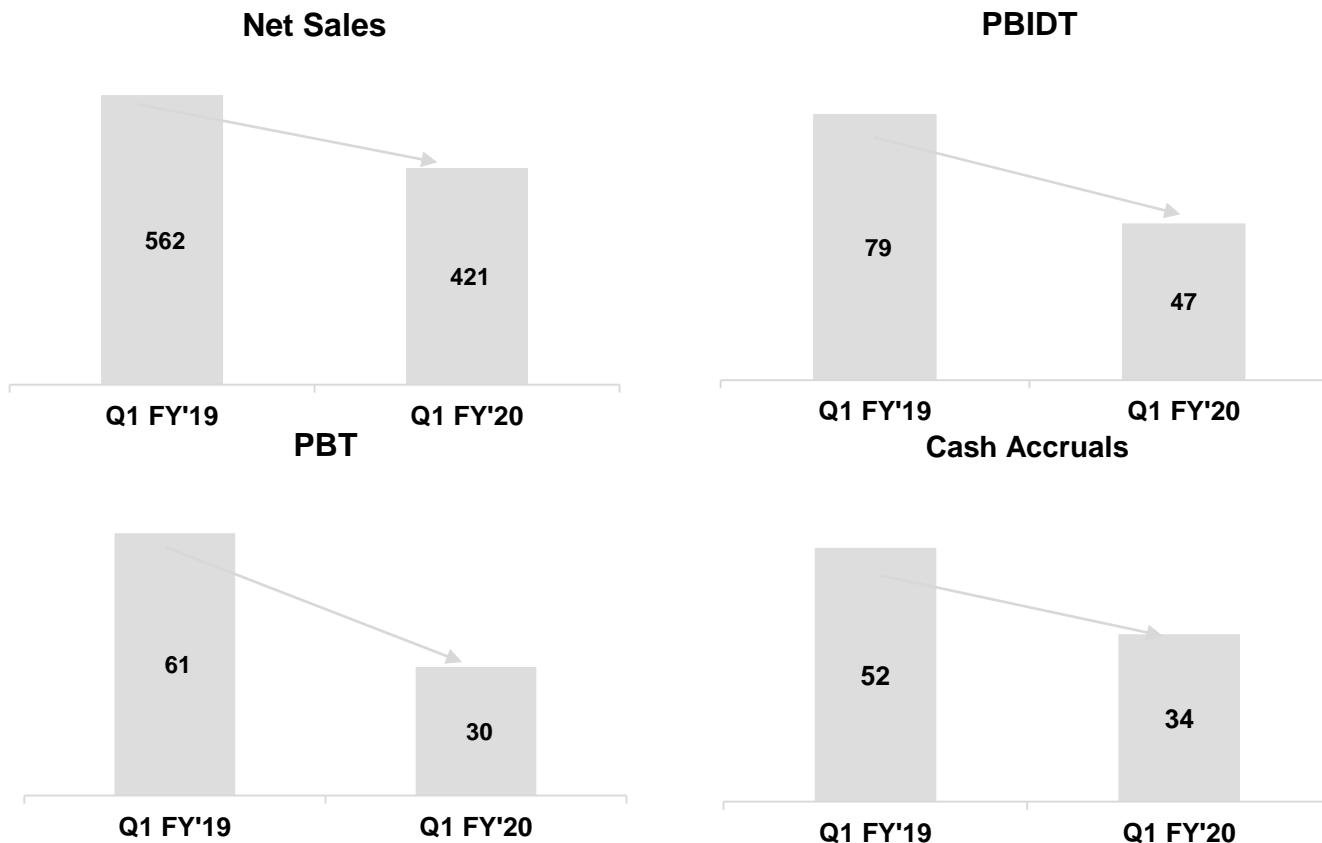

Cash Accruals: PAT+ Depreciation

Future ready for growth...

Financial Result – Q1 FY'20



All Figures in Rupees Crore

Revenue and Profitability Indicators						
Particulars	2018-19	2019-20	2018-19	2018-19	% Growth	% Growth
	12M	Q1	Q1	Q4	Q1 FY'20 Vs Q1 FY'19	Q1 FY'20 Vs Q4 FY'19
Net Sales	2,135	421	562	543	-25%	-23%
PBIDT	287	47	79	71	-40%	-33%
Operating Margin	241	34	67	58	-49%	-42%
PBT	215	30	61	54	-51%	-44%
PAT	137	20	40	33	-49%	-39%
Cash Accruals	184	34	52	45	-35%	-26%
PBDITA Margin (%)	13%	11%	14%	13%		
Operating Margin (%)	11%	8%	12%	11%		
PBT (%)	10%	7%	11%	10%		
PAT (%)	6%	5%	7%	6%		
Cash Accruals (%)	9%	8%	9%	8%		

Key Capital indicators		
Particulars	Q1'20	Q4'19
TOL/TNW	1.0	1.1
Debt to Equity	0.1	0.0
Average Cost of Borrowing	8.5%	8.8%

Cash Accruals: PAT+ Depreciation

Future ready for growth...

CSR Achievements made in Q1 FY'19:

Environment: Planted 3800 saplings, distributed jute bags and glass bottles and water canes to our beneficiaries all locations on occasion of World Environment Day

Education: Improved facilities in 15 government schools in Haryana by renovating class rooms, teaching aids, water tanks, ground and toilets

Sports: Our sponsored star sports person Pooja Raghav participated in Taekwondo Open International Tournament and qualified for International Tournament.

Community Outreach: More than 86 trainees awarded certificate after successfully completing their basic and advance course in sewing & computer in Delhi, Gurgaon and Jamshedpur.



Distributing water canes to needy community people on occasion of World Environment Day in Delhi.



Distributing books to needy students in Govt Sr. Sec. School, Yamuna Nagar



Almost 1280 beneficiaries were screened for oral cancer at various locations in collaboration with Yuvraj Singh Foundation



Planting saplings by involving our employees in Jamshedpur

Forward Looking Statement

This presentation is made to enable investors to comprehend our prospects and take informed investment decisions. This presentation may contain certain forward looking statements within the meaning of applicable laws and regulations. We cannot guarantee that these forward-looking statements will be realized, although we believe we have been prudent in assumptions. The achievement of results is subject to risks, uncertainties and even inaccurate assumptions. Should known or unknown risks or uncertainties materialize, or should underlying assumptions prove inaccurate, actual results could vary materially from those anticipated, estimated or projected. Readers should bear this in mind. We undertake no obligation to publicly update any forward-looking statements, whether as a result of new information, future events or otherwise.

Thank You