

Jamna Auto Industries Ltd



Company Profile

Jamna Auto Industries Ltd

Sales

Jamna Auto – INR 1,250 Cr

**Market
Capitalization**

INR 1,100 Cr Approx.
(Share Price INR 140/-)

**Production
Spring Capacity**

2013 – 150,000 MT
2014 – 180,000 MT

3rd in the World

Alliance

Ridewell (USA) – Air Suspension & Lift Axle

**Manufacturing
Plants**

7 Plants in 6 States

**Listed on Stock
Exchanges**

BSE – 520051
NSE – JAMNAAUTO



Global Spring Manufacturers

Indian Market Scenario

SOB

Jamna Auto
66%

Others
34%

1980's

Leaf Spring Manufacturer	Base Country	Capacity
<u>NHK Spring Co. Ltd.</u>	Japan	2,00,000
Delphi	USA	1,00,000
Eaton/Oxford	Canada	1,00,000
Krupp	Germany	40,000
<u>Hendrickson</u>	USA	40,000
DSP	USA	40,000
Rejna	Europe	40,000
Hoesh	Germany	30,000
Sarfedern	Germany	20,000
Johns Woodhead	UK	10,000

Current

Leaf Spring Manufacturer	Base Country	Capacity
Rassini	Mexico	2,50,000
Hendrickson	Canada & Mexico	1,90,000
Jamna Auto Industries Ltd.	India	1,80,000
NHK Spring Co. Ltd.	Japan & Thailand	1,50,000
Ventanna	Europe	1,10,000
Dong Feng	China	1,05,000
FAW	China	1,00,000
MBHA	Spain	36,000
Olgin	Turkey	28,000
LPDN	Europe	24,000

Jamna Auto Industries Ltd - Shareholding

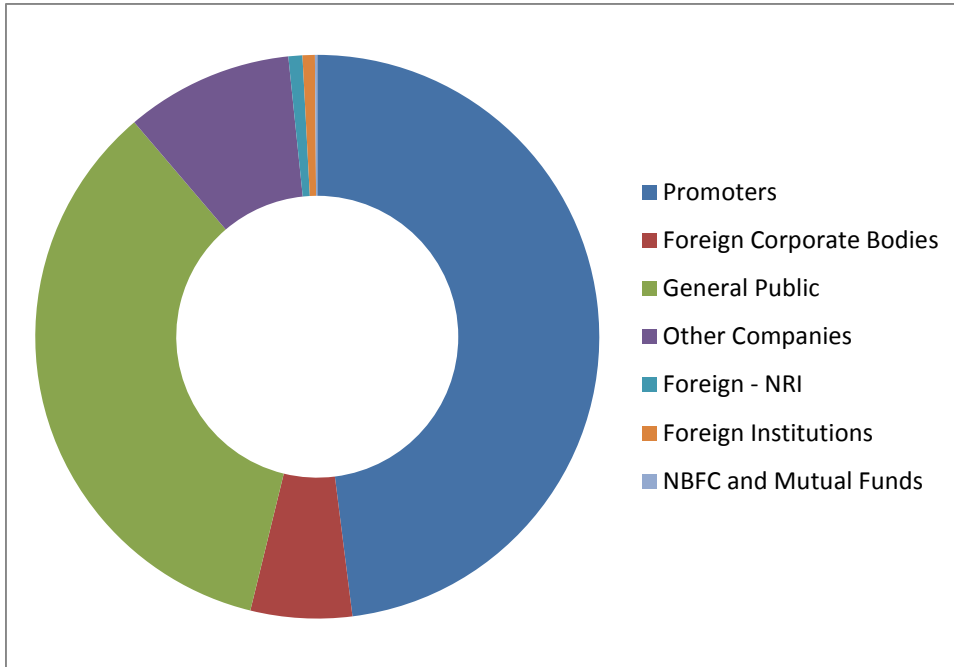

Category	No. of Shares	Percentage
Promoters	3,81,54,630	48.01
Foreign Corporate Bodies	46,17,018	5.81
General Public	2,77,72,602	34.94
Other Companies	76,30,723	9.60
Foreign - NRI	6,36,529	0.80
NBFC and Mutual Funds	5,60,160	0.70
Financial Institutions	1,06,300	0.13
Total	7,94,77,962	100.00

JAI's Strength

OEM Market Share 66%, OEM Share in Parabolic: 95%

Manufacturing more than 350 Parts

Industry Leader (in India) nearest competitor 15 % Market Share

Strategically located all over India

FY 16 estimated Sales INR 1,250 Cr & Installed Capacity 180,000 MT p.a.

Products

Current Products

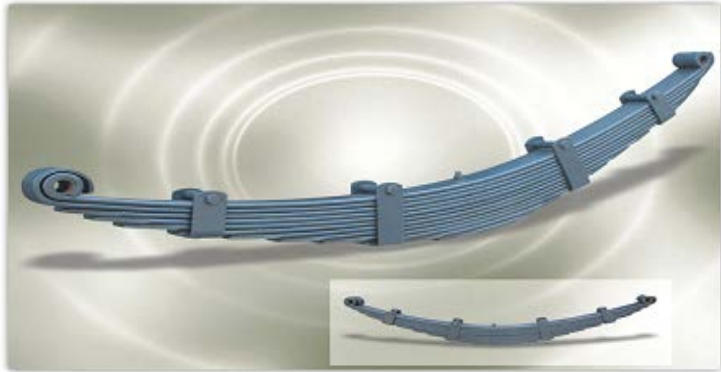

Conventional Leaf spring

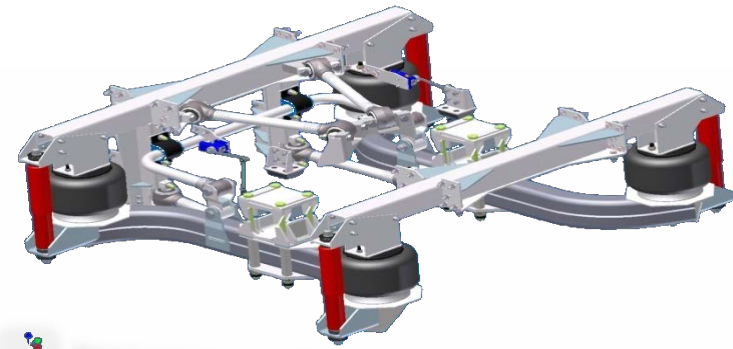

Air Suspension



Parabolic Leaf Spring



Lift Axle

Presence

Locations

Products

Markets

Main Plants

- ❖ Yamuna Nagar
- ❖ Malanpur
- ❖ Chennai
- ❖ Jamshedpur
- ❖ Pune (Plant & R&D Centre)

Assembly Plants

- ❖ Pant Nagar
- ❖ Hosur

- ❖ Leaf Spring
- ❖ Parabolic Spring
- ❖ Lift Axle
- ❖ Air Suspension

- ❖ OE India
- ❖ AM India
- ❖ OE – Exports
- ❖ AM – Exports

7 Locations

4 Products

4 Markets

* OE India- Original Equipment Manufacturer

* AM India – After Market India

 **Serving more than 20 OEM Customer Locations in India**

Domestic Customers



Ashok Leyland



AMW
THE GLOBAL TRUCK

NISSAN



ASHOK LEYLAND
A KIRLOSKAR GROUP COMPANY



SML
ISUZU



RENAULT NISSAN



TATA

VE COMMERCIAL VEHICLES

A VOLVO GROUP AND EICHER MOTORS JOINT VENTURE

International Customers



ISUZU

Your responsible partner



UD TRUCKS



JAI & OEMs Presence in India

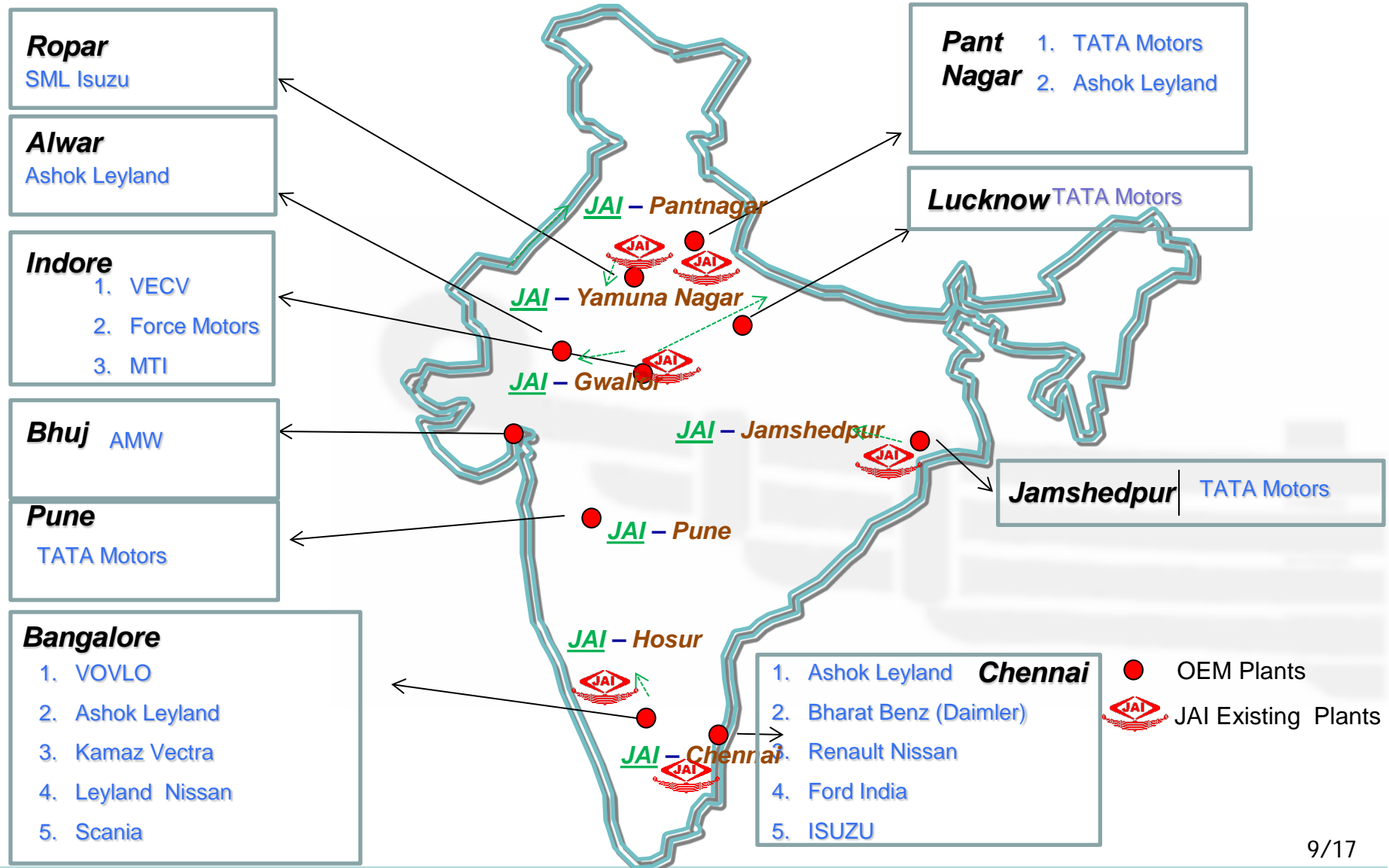

Project Lakshya

Jai's medium term strategy focused on value creation



Jamna Auto Industries Ltd



Q3 Update

2015-16

Jamna Auto Industries Ltd

9 Months Highlights

- Upgradation of Credit Ratings by ICRA

Long Term Rating from [ICRA]A- to [ICRA] AA-

Short Term Rating from [ICRA]A2+ to [ICRA]A1+

- Healthy Liquidity

	INR in Cr
Unutilized Working Capital Limits (PO Finance & Cash Credit)	36
BOE/Discountable Invoices in hand (Volvo, Nissan, SML, VE Commercial)	6
Balance in Current Accounts	5
Total	47



Since Jamna is into CV Industry which is cyclical in nature, these funds will be used for better cash flow management during down trend

Note: Above liquidity is after Steel Buying of INR 31 Cr done on Cash Discount basis in Q3.

Jamna Auto Industries Ltd

Borrowing Trend

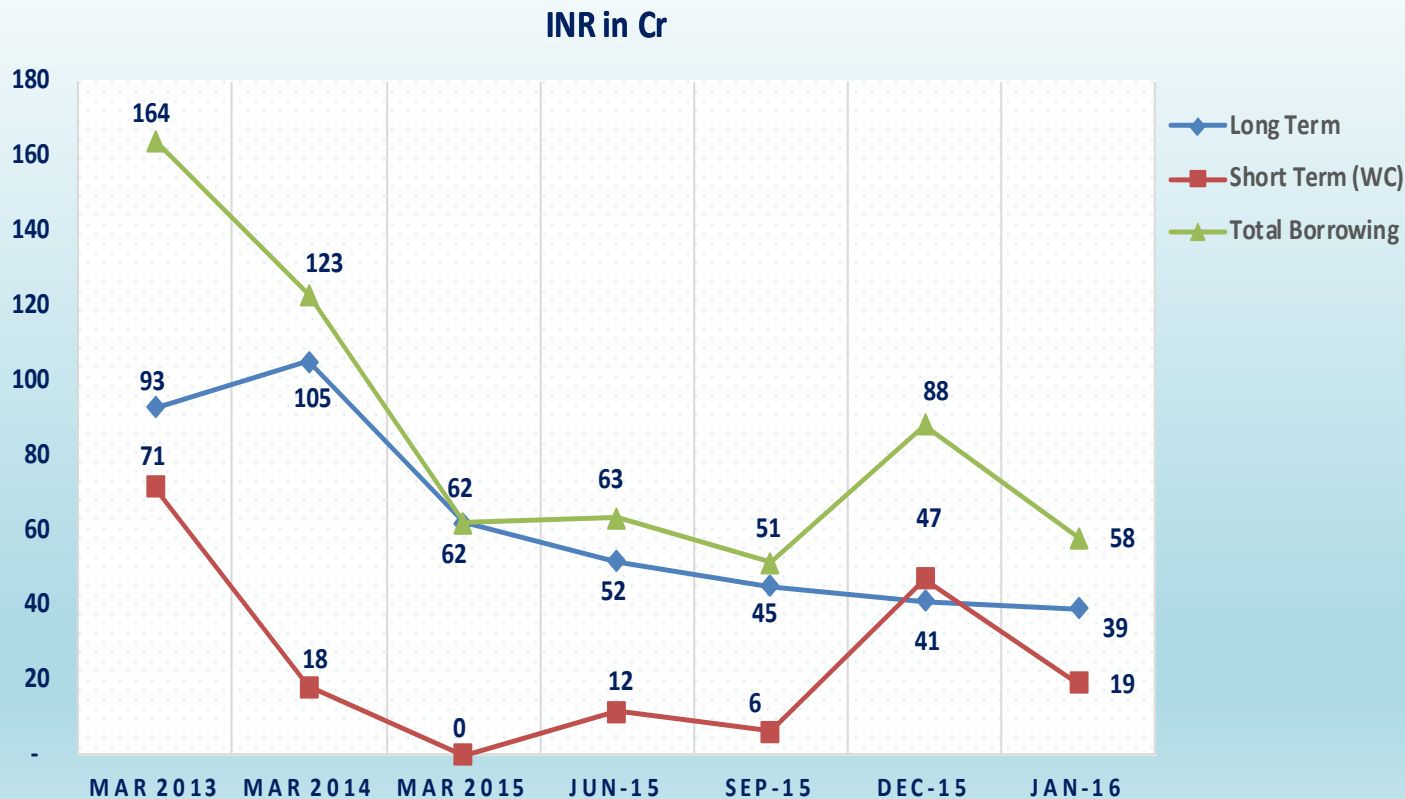

- Current year Capex of INR 75 Cr will be met out of internal cash generations
- Capex incurred till date INR 52 Cr

Note: a) Long Term Debt as on 31.12.2015 includes one year Term Loan liability of INR 35 Cr
 b) Figures shown above are excluding Buyer's credit for RM imports.

Jamna Auto Industries Ltd

Commercial Vehicle Trends & Market Share

	9m 2014-15	9m 2015-16	9m Growth	Growth in 2014-15
M & HCV Production (Nos.)	1,86,221	2,38,115	28%	21%
LCVs (Nos.)	3,17,310	3,46,873	9%	-10%
Vehicle Production (Nos.)	5,03,531	5,84,988	16%	-0.3%
Spring Demand (MTs)	1,13,989	1,26,255	11%	20%
JAI 's Business (MTs) - OEM	71,813	83,328	16%	33%
Market Share (%)	63	66	3%	6%

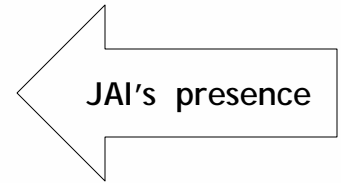

Vehicle Production information source : SIAM

Jamna Auto Industries Ltd

Sales Comparison (In MTs)

Springs (Figures in MT)

Segment	2014-15		2015-16		2014-15		2015-16	
	Q3	%	Q3	%	9m	%	9m	%
OEM	24,593	81.5%	24,928	79.6%	71,813	82.3%	83,328	82.9%
Replacement	5,569	18.5%	6,379	20.4%	15,429	17.7%	17,181	17.1%
Total	30,162	100%	31,307	100%	87,242	100%	1,00,509	100%

Growth

4%

15%

Net Sales (INR in Cr) (Standalone)

2014-15	2015-16	2014-15
9m	9m	FY
677	771	979

Growth

14%

Net Sales (INR in Cr) (Consolidated)

2014-15	2015-16	2014-15
9m	9m	FY
753	889	1,095

Growth

18%

Jamna Auto Industries Ltd

Financial Results (Standalone)

Standalone Q3

	INR in Cr			
	2014-15 Q3	2015-16 Q-2	2015-16 Q3	Growth* in %
Net Sales	234.2	275.4	241.3	3%
Export Sales	2.2	1.5	2.8	29%
EBITDA	20.2	34.0	34.0	68%
Operating Margin	13.4	22.5	21.7	62%
PBT	9.2	18.9	18.3	99%
PAT	5.7	15.3	15.0	163%
Cash Accruals	12.5	26.8	27.4	118%
<hr/>				
EBITDA Margin (%)	8.6%	12.4%	14.1%	64%
Operating Margin (%)	5.7%	8.2%	9.0%	57%
PBT (%)	3.9%	6.9%	7.6%	93%
PAT (%)	2.4%	5.5%	6.2%	156%
Cash Accruals	5.3%	9.7%	11.3%	112%

* Growth over Q3 of 2014-15

9 Months

	INR in Cr			
	2014-15 FY	2014-15 9m	2015-16 9m	Growth* in %
Net Sales	979.2	677.3	770.9	14%
Export Sales	10.8	8.5	7.0	-18%
EBITDA	86.0	50.0	95.7	91%
Operating Margin	56.7	30.9	64.0	107%
PBT	39.8	18.2	54.2	198%
PAT	29.4	14.3	44.2	209%
Cash Accruals	58.7	33.4	75.9	127%
<hr/>				
EBITDA Margin (%)	8.8%	7.4%	12.4%	68%
Operating Margin (%)	5.8%	4.6%	8.3%	82%
PBT (%)	4.1%	2.7%	7.0%	162%
PAT (%)	3.0%	2.1%	5.7%	172%
Cash Accruals (%)	6.0%	4.9%	9.8%	100%

* Growth over 9m of 2014-15

Jamna Auto Industries Ltd

Financial Results (Consolidated)

Consolidated Q3

	INR in Cr			
	2014-15 Q3	2015-16 Q2	2015-16 Q3	Growth* in %
Net Sales	262.1	317.7	281.6	7%
Export Sales	2.2	1.5	2.8	29%
EBITDA	22.3	37.7	38.5	73%
Operating Margin	15.2	25.9	25.8	71%
PBT	10.7	22.2	22.1	107%
PAT	5.4	15.3	15.5	185%
Cash Accruals	12.6	27.1	28.2	123%
<hr/>				
EBITDA Margin (%)	8.5%	11.9%	13.7%	61%
Operating Margin (%)	5.8%	8.2%	9.2%	59%
PBT (%)	4.1%	7.0%	7.8%	93%
PAT (%)	2.1%	4.8%	5.5%	165%
Cash Accruals	4.8%	8.5%	10.0%	108%

* Growth over Q3 of 2014-15

9 Months

	INR in Cr			
	2014-15 FY	2014-15 9m	2015-16 9m	Growth* in %
Net Sales	1,095.0	753.0	889.4	18%
Export Sales	10.8	8.5	7.0	-18%
EBITDA	96.5	56.7	106.4	88%
Operating Margin	65.4	36.1	73.7	104%
PBT	47.4	22.5	63.0	180%
PAT	29.4	14.1	43.6	210%
Cash Accruals	60.5	34.6	76.4	121%
<hr/>				
EBITDA Margin (%)	8.8%	7.5%	12.0%	59%
Operating Margin (%)	6.0%	4.8%	8.3%	73%
PBT (%)	4.3%	3.0%	7.1%	137%
PAT (%)	2.7%	1.9%	4.9%	162%
Cash Accruals (%)	5.5%	4.6%	8.6%	87%

* Growth over 9m of 2014-15



Thank You